

WPM 2006 plus WPM 2006 R WPM 2007 plus WPM 2007 R

**Montage- und
Inbetriebnahmeanweisung**
für den Installateur

**Installation and
start-up Instructions**
for technicians

**Instructions de montage
et de mise en service**
pour l'installateur

Deutsch

English

Français

WPM 2007 - Norm NTC-2 / NTC-10 (Fühler / sensor / sonde)

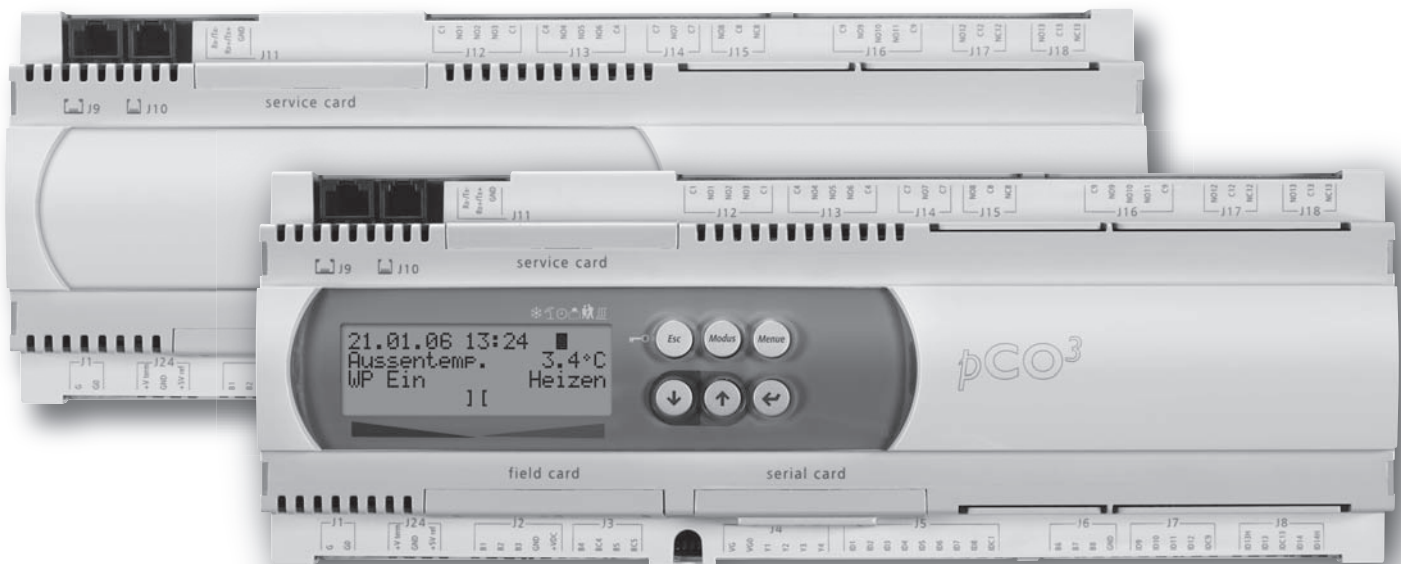

WPM 2006 - Norm NTC-2 / Norm NTC-2 (Fühler / sensor / sonde)

Wärmepumpen- Manager

für Nieder-, Mittel- und
Hochtemperatur-Wärme-
pumpen zum Heizen und
Kühlen

Heat pump manager

for low, medium and high
temperature heat pumps
for heating and cooling

Gestionnaire de pompe à chaleur

pour pompes à chaleur
à température basse,
moyenne ou haute
pour le chauffage et
le rafraîchissement

DE Einstellung der Sprache

- MENEUE-Taste für einige Sekunden gedrückt halten
- Auswahl des Menüpunktes *1 Einstellungen* mit den Pfeiltasten (↑ und ↓) und bestätigen durch Drücken der ENTER-Taste (↵)
- Auswahl des Untermenüpunktes *Sprache* mit den Pfeiltasten (↑ und ↓) und bestätigen durch Drücken der ENTER-Taste (↵) bis Cursor zum Einstellwert springt
- Gewünschte Sprache mit Pfeiltasten (↑ und ↓) einstellen
- Gewählte Sprache mit ENTER-Taste (↵) bestätigen oder durch die ESC-Taste verwerfen

GB How to set the desired language

- Hold MENEUE button depressed for several seconds
- Select the *1 Einstellungen* menu item with the arrow buttons (↑ and ↓) and confirm by pressing the ENTER button (↵)
- Select the *Sprache* submenu item with the arrow buttons (↑ and ↓) and confirm by pressing the ENTER button (↵)
- Set the desired language with the arrow buttons (↑ and ↓)
- Confirm the selected language with the ENTER button (↵) or revoke with the ESC button

FR Réglage de la langue

- Tenir appuyée la touche MENU pendant quelques secondes
- Sélectionner l'option *1 Einstellungen* avec les touches pourvues de flèches (↑ et ↓) puis confirmer avec la touche ENTREE (↵)
- Sélectionner l'option *Sprache* avec les touches pourvues de flèches (↑ et ↓) puis confirmer avec la touche ENTREE (↵)
- Régler la langue souhaitée avec les touches pourvues de flèches (↑ et ↓)
- Confirmer la langue avec la touche ENTREE (↵) ou rejeter la sélection avec la touche ECHAP

SI Nastavení jazyka

- Stiskněte na několik sekund klávesu MENU.
- Zvolte bod menu *1 Einstellungen* pomocí kláves se šipkami (↑ a ↓) a potvrďte jej stisknutím klávesy ENTER (↵).
- Zvolte bod podmenu *Sprache* pomocí kláves se šipkami (↑ a ↓) a potvrďte jej stisknutím klávesy ENTER (↵), dokud nepřeskočí kurzor na nastavení hodnoty.
- Nastavte potřebné jazyky pomocí kláves se šipkami (↑ a ↓).
- Potvrďte zvolené jazyky klávesou ENTER (↵) nebo je zrušte klávesou ESC.

IT Impostare la lingua

- Tenere premuto per qualche secondo il pulsante MENEUE
- Selezionare la voce di menu *1 Einstellungen* con i pulsanti a freccia (↑ e ↓), confermare premendo il pulsante INVIO (↵)
- Selezionare la voce sottomenu *Sprache* con i pulsanti a freccia (↑ e ↓), confermare premendo pulsante INVIO (↵) finché il cursore si troverà sul valore dell'impostazione
- Settare la lingua desiderata con i pulsanti a freccia (↑ e ↓)
- Con il pulsante INVIO (↵) confermare la lingua selezionata oppure annullare con il pulsante ESC.

NL De taal instellen

- De MENU-toets enkele seconden ingedrukt houden
- Het menupunt *1 Einstellungen* met de pijltjestoetsen (↑ en ↓) selecteren en bevestigen door middel van de ENTER-toets (↵)
- Het submenupunt *Sprache* met de pijltjestoetsen (↑ en ↓) selecteren en bevestigen door middel van de ENTER-toets (↵) tot de cursor naar de instellingswaarde springt
- De gewenste taal met de pijltjestoetsen (↑ en ↓) instellen
- De geselecteerde taal met de ENTER-toets (↵) bevestigen of door de ESC-toets afwijzen

SE Inställning av språk

- Håll MENEUE-tangenten intryckt några sekunder
- Välj menyposten *1 Einstellungen* med piltangenterna (↑ och ↓) och bekräfta genom att trycka på ENTER-tangenten (↵)
- Välj undermenyposten *Sprache* med piltangenterna (↑ och ↓) och bekräfta genom att trycka på ENTER-tangenten (↵) till dess att markören flyttar sig till "Inställningsvärde"
- Ställ in önskat språk med piltangenterna (↑ och ↓)
- Bekräfta det valda språket med ENTER-tangenten (↵) eller välj bort det med hjälp av ESC-tangenten

CZ Nastavitev jezika

- MENEUE -Típkou držimo nekaj sekund pritisnjeno.
- Izbiro tipk za meni *1 Einstellungen* s pomočjo tipk (↑ in ↓) in potrjujemo s pomočjo tipke ENTER (↵).
- Pojem izbiramo s pomočjo tipk označenih s puščico (↑ in ↓) in potrjujemo s pomočjo tipke ENTER (↵), dokler se puščica ne postavi na izbrano mesto.
- Želeni jezik uravnavamo s tipkama (↑ in ↓).
- Izbrani jezik s tipko ENTER (↵) potrdimo ali s tipko ESC odklonimo.

PL Ustawienia języka

- Przycisk MENU wcisnąć i przytrzymać na kilka sekund
- Wybór punktu menu *1 Einstellungen* przy pomocy klawiszy strzałek (↑ i ↓) i potwierdzenie wciśnięciem klawisza ENTER (↵)
- Wybór punktu podmenu *Sprache* przy pomocy klawiszy strzałek (↑ i ↓) i potwierdzenie wciśnięciem klawisza ENTER (↵) aż kursor przeskoczy na wartość ustawianą
- Ustawić pożądaną język klawiszami strzałek (↑ i ↓)
- Potwierdzić pożądaną język klawiszem ENTER (↵) lub porzucić wciśnięciem klawisza ESC

RC 语言设置

- 按住菜单键几秒钟
- 菜单选项的选择 "*1 Einstellungen*" 调上下箭头键 (↑ 和 ↓), 然后按确认键 (↵) 确认
- 次级菜单选项的选择 "*Sprache*" 调上下箭头键 (↑ 和 ↓), 然后按确认键 (↵) 直到光标跳到调整值
- 调上下箭头键 (↑ 和 ↓) 来设置所需语言
- 用确认键 (↵) 来确认所选语言, 或者通过ESC-键拒绝对这个语言的选择。

PT Definição do idioma

- Manter a tecla MENEUE premeida durante alguns segundos
- Seleção do ponto do menu *1 Einstellungen* através das teclas de setas (↑ e ↓) e confirmar premindo a tecla ENTER (↵)
- Seleção do ponto do submenu *Sprache* das teclas de setas (↑ e ↓) e confirmar premindo a tecla ENTER (↵) até o cursor saltar para o valor de definição
- Definir o idioma pretendido através das teclas de setas (↑ e ↓)
- Confirmar o idioma seleccionado através da tecla ENTER (↵) ou cancelar através da tecla ESC

ES Seleccionar el idioma

- Mantener pulsada la tecla MENEUE durante algunos segundos
- Seleccionar la opción *1 Einstellungen* con las teclas de flecha (↑ y ↓) y confirmar pulsando la tecla ENTER (↵)
- Seleccionar la subopción *Sprache* con las teclas de flecha (↑ y ↓) y confirmar pulsando la tecla ENTER (↵) hasta que el cursor salte al valor de ajuste
- Configurar el idioma deseado con las teclas de flecha (↑ y ↓)
- Confirmar el idioma elegido con la tecla ENTER (↵) o desechar la selección de idioma pulsando la tecla ESC

Table of contents

1	Important Information	E-3
2	Heat Pump Manager: Scope of Supply	E-3
3	Installation	E-3
3.1	Attaching the Wall-Mounted Heat Pump Manager (Heating)	E-3
3.2	Temperature Sensor (Heating Controller N1)	E-4
3.2.1	Heating controller with integrated display (WPM 2006)	E-4
3.2.2	Heating controller with removable control panel (WPM 2007)	E-4
3.2.3	Mounting the external temperature sensor	E-5
3.2.4	Installing the strap-on sensor	E-5
4	Electrical Installations for the Heat Pump	E-6
5	Preconfiguring the Heat Pump Heating System	E-8
5.1	Menu	E-8
5.2	Coding	E-9
6	Configuring the Heat Pump Heating System	E-10
6.1	Settings	E-10
6.2	Outputs	E-17
6.3	Inputs	E-18
6.4	Special Functions	E-19
6.5	Modem / PC Link	E-21
7	Energy-Efficient Operation	E-22
7.1	Setting a Heating Curve on the Basis of the External Temperature	E-22
7.1.1	Setting examples	E-23
7.1.2	Heating Curve Optimization	E-24
7.2	Regulation via Room Temperature	E-24
7.3	Fixed-Setpoint Regulation / Setting a Horizontal Heating Characteristic Curve	E-24
8	Domestic Hot Water Preparation	E-25
8.1	Basic Heating Using the Heat Pump	E-25
8.1.1	Attainable hot water temperatures	E-25
8.1.2	Hot water temperatures dependent on the heat source	E-25
8.2	Reheating with Flange Heater/2nd Heat Generator	E-25
8.3	Thermal Disinfection	E-26
9	Program Description	E-26
9.1	Faults	E-26
9.2	Limit Temperature (Bivalence Point)	E-26
9.3	Utility Block / Heat Pump Operation Block	E-26
9.4	Control of the 2nd Heat Generator	E-27
9.4.1	Control of immersion heaters	E-27
9.4.2	Constantly regulated boiler (mixer regulation)	E-27
9.4.3	Variably-regulated (gliding) boiler (burner regulation)	E-27
9.4.4	Special program for older boilers and main cylinder systems	E-27
9.4.5	Bivalent-renewable	E-27
9.5	Power Regulation	E-28
9.5.1	Heat pumps with one compressor	E-28
9.5.2	Heat pumps with two compressors	E-28
9.5.3	High-temperature air-to-water heat pumps	E-28
9.6	Hysteresis	E-29
9.7	Control of Circulating Pumps	E-29
9.7.1	Heat circulating pump/antifreeze (frost protection)	E-29
9.7.2	Hot water circulating pump	E-29
9.7.3	Swimming pool water circulating pump	E-29
9.7.4	Auxiliary circulating pump	E-30

9.7.5 Primary Pump for Heat Source	E-30
10 Start-Up: Air-to-Water Heat Pumps	E-30
11 Initial Heating Program (Drying of Screed Flooring)	E-30
11.1 Implementing the Heat Pump Heating System Directive.....	E-30
11.2 Initial Heating According to DIN EN 1264-4.....	E-31
11.3 Drying of Screed Floors	E-31
11.3.1 General information.....	E-31
11.3.2 Standard program for screed drying.....	E-31
11.3.3 Individual program for screed drying.....	E-32
12 Extended Installation Instructions for the Heat Pump Manager (Heating/Cooling).....	E-32
12.1 Heating and Cooling Controller.....	E-32
12.1.1 Network operation of heating and cooling controllers and remote control	E-32
12.1.2 Temperature sensor (cooling controller)	E-33
12.2 Cold Generation by Active Cooling.....	E-33
12.2.1 Heat pumps without additional heat exchangers.....	E-33
12.2.2 Heat Pumps with Additional Heat Exchangers for Waste Heat Recovery.....	E-33
12.3 Cold Generation via Passive Cooling	E-33
12.4 Cooling Program Description.....	E-34
12.4.1 Cooling operating mode	E-34
12.4.2 Activation of cooling functions	E-34
12.4.3 Deactivation of circulating pumps in cooling operation	E-34
12.4.4 Silent and dynamic cooling.....	E-34
12.5 Regulation of the Room Temperature	E-34
13 Special Accessories	E-35
13.1 Remote Control.....	E-35
13.2 Remote Diagnostic System (FDS).....	E-35
13.3 Room Climate Control Station	E-35
Anhang / Appendix / Annexes	A-I

1 Important Information

- During start-up, observe the respective national safety regulations and the applicable VDE safety regulations, particularly VDE 0100 as well as the technical connection requirements of the utility companies and network operators!
- The heat pump controller should only be operated in dry rooms with temperatures ranging between 0 °C and 35 °C. Ensure that no condensation forms on the device.
- All sensor connecting leads with a conductor cross-section of 0.75 mm can be extended to a maximum of 30 m. Sensor leads should not be installed next to power cables.
- To ensure that the antifreeze function of the heat pump works properly, the heat pump controller must remain connected to the power supply and the flow must be maintained through the heat pump at all times.
- The switching contacts of the output relays are interference-suppressed. Therefore, depending on the internal resistance of the measuring instrument, a voltage can also be measured when the contacts are open. However, this will be much lower than the supply voltage.
- The terminals J1 to J7 and J11, and the plug connectors X2, X3 and X8 are connected to extra-low voltage. If the supply voltage is connected to these terminals because of a wiring error, the heat pump controller will be destroyed.

2 Heat Pump Manager: Scope of Supply

The heat pump manager is available in three versions.

- Integrated in the heat pump casing
- Wall-mounted heat pump manager for a heat pump heating system
- Wall-mounted heat pump manager for a heat pump system for heating and cooling (*Chap. 12 on p. 32*).

The scope of supply of the wall-mounted heat pump manager includes:

- Heat pump manager with casing
- 3 dowels (6 mm) with screws for wall mounting
- External temperature sensor
- Operator's manual and operating instructions for users
- Installation and start-up instructions for technicians

3 Installation

3.1 Attaching the Wall-Mounted Heat Pump Manager (Heating)

The controller is attached to the wall with the 3 screws and dowels (6 mm) included in the scope of supply. The following mounting procedure should be used to avoid soiling or damaging the controller:

- Mount the dowels for the upper fastening eye at operator level.
- Screw the screw into the dowel so that the controller can be hung up.
- Hang the controller on the upper fastening eye.
- Mark the position of the side fastening eyes.
- Remove the controller.
- Mount the dowels for the side fastening eyes.
- Rehang the controller and tighten the screws.

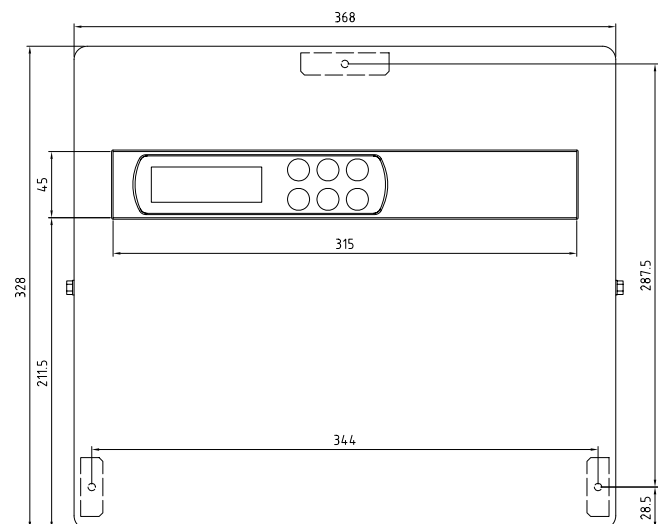

Fig. 3.1: Dimensions of the wall-mounted heat pump manager (heating)

3.2 Temperature Sensor (Heating Controller N1)

Depending on the type of heat pump implemented, the following temperature sensors are already installed or must be additionally mounted:

- Outside temperature (R1) (see *Chap. 3.2.3 on p. 5*)
- Temperature 1st, 2nd und 3rd heating circuit (R2, R5 and R13) (see *Chap. 3.2.4 on p. 5*)
- Flow temperature (R9), as flow sensor in the case of air-to-water heat pumps

- Outlet temperature of the heat source in the case of brine-to-water and water-to-water heat pumps
- Hot water temperature (R3)
- Temperature of regenerative heat accumulator (R13)

The heating controller N1 is available in 2 versions:

- Heating controller with integrated display (WPM 2006) (see *Chap. 3.2.1 on p. 4*)
- Heating controller with removable control panel (WPM 2007) (see *Chap. 3.2.2 on p. 4*)

	Temperature [°C]																
	-20	-15	-10	-5	0	5	10	15	20	25	30	35	40	45	50	55	60
Standard NTC-2 in kΩ	14.6	11.4	8.9	7.1	5.6	4.5	3.7	2.9	2.4	2.0	1.7	1.4	1.1	1.0	0.8	0.7	0.6
Standard NTC-10 in kΩ	67.7	53.4	42.3	33.9	27.3	22.1	18.0	14.9	12.1	10.0	8.4	7.0	5.9	5.0	4.2	3.6	3.1

3.2.1 Heating controller with integrated display (WPM 2006)

All temperature sensors to be connected to the heating controller with integrated display must correspond to the sensor characteristic curve shown in *Fig. 3.3 on p. 4*.



Fig. 3.2: Heating controller with integrated display

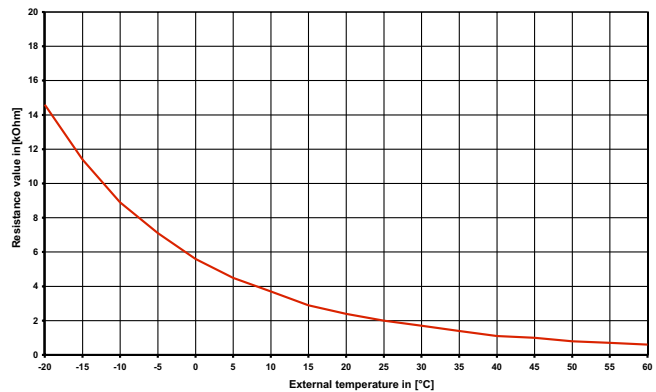

Fig. 3.3: Sensor characteristic curve standard NTC-2 according to DIN 44574 for connecting temperature sensors to the heating controller with integrated display

3.2.2 Heating controller with removable control panel (WPM 2007)

All temperature sensors to be connected to the heating controller with removable control panel must correspond to the sensor characteristic curve shown in *Fig. 3.5 on p. 4*. The only exception is the external temperature sensor included in the scope of supply of the heat pump (see *Chap. 3.2.3 on p. 5*)



Fig. 3.4: Removable control panel

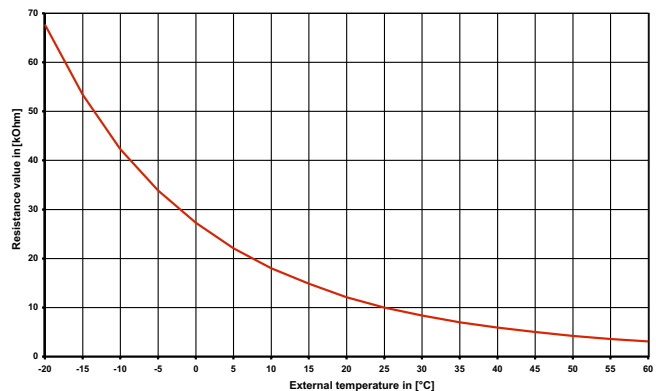

Fig. 3.5: Sensor characteristic curve NTC-10 for connecting temperature sensors to the heating controller with removable control panel

3.2.3 Mounting the external temperature sensor

The temperature sensor must be mounted so that all weather conditions are taken into consideration and the measured value is not falsified.

Installation:

- On the external wall of a heated room used as living space, if possible on the north or north-west side of the building
- Not in a “sheltered position” (e.g. niche in a wall or under a balcony)
- Not in the vicinity of windows, doors, exhaust air vents, external lighting or heat pumps
- Must not be exposed to direct sunlight at any time of year

3.2.4 Installing the strap-on sensor

It is only necessary to mount the strap-on sensors if they are included in the scope of supply of the heat pump, but have not yet been installed.

The strap-on sensors can be fitted as pipe-mounted sensors or installed in the immersion sleeve of the compact manifold.

- Remove paint, rust and scale from heating pipe.
- Coat cleaned surface with heat transfer compound (apply sparingly).
- Attach sensor with hose clip (tighten firmly as loose sensors can cause malfunctions) and thermally insulate.

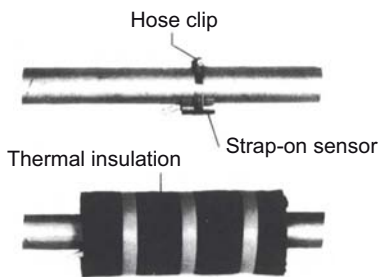

Fig. 3.7: Mounting a pipe-mounted sensor

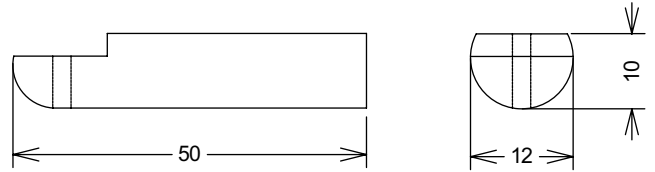

Fig. 3.6: Dimensions of the external sensor in insulated casing

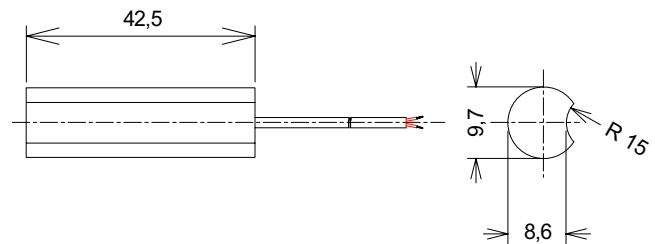

Fig. 3.8: Dimensions of the strap-on sensor standard NTC-2 in a metal casing

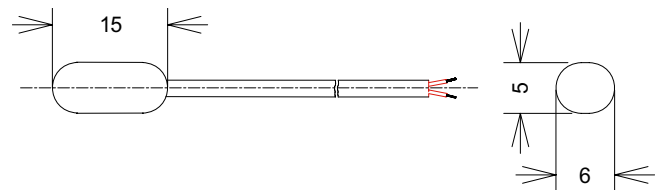

Fig. 3.9: Dimensions of the strap-on sensor NTC-10 in a plastic casing

Compact manifold:

The return flow sensor should be installed in the immersion sleeve if a compact manifold is used in combination with the wall-mounted heat pump manager. Any empty space between the sensor and the immersion sleeve should be filled completely with heat transfer compound. Further information can be found in the compact manifold installation instructions.

4 Electrical Installations for the Heat Pump

- 1) The three-core or four-core supply cable for the output section of the heat pump is fed from the heat pump meter via the utility blocking contactor (if required) into the heat pump (1L/N/PE~230 V, 50 Hz or 3L/PE~400 V, 50 Hz). The system must be protected according to the power consumption data on the type plate using an all-pole circuit breaker **of the phases with C characteristic and common tripping** for all 3 paths. Cable cross section in compliance with DIN VDE 0100.
- 2) The three-core **supply cable** for the **heat pump manager** (N1 heating controller) is fed into the heat pump (device with integrated controller) or to the future mounting location of the heat pump manager (HPM). The (L/N/PE~230 V, 50 Hz) supply cable for the heat pump manager must have a constant voltage. For this reason, it should be tapped upstream from the utility blocking contactor or be connected to the household current, because otherwise important protection functions could be lost during a utility block.
- 3) The **utility blocking contactor** (K22) with 3 main contacts (1/3/5 // 2/4/6) and an auxiliary contact (NO contact 13/14) should be dimensioned according to the heat pump output and must be supplied by the customer. The NO contact of the utility blocking contactor (13/14) is looped from terminal strip X2 to the connector terminal J5/ID3. **CAUTION! Extra-low voltage!**
- 4) The **contactor** (K20) for the **immersion heater** (E10) of mono energy systems (HG2) should be dimensioned according to the radiator output and **must be supplied by the customer**. It is controlled (230 V AC) by the heat pump manager via the terminals X1/N and J13/NO 4.
- 5) The **contactor** (K21) for the **flange heater** (E9) in the hot water cylinder should be dimensioned according to the radiator output and **must be supplied by the customer**. It is controlled (230 V AC) by the heat pump manager via the terminals X1/N and J16/NO 10.
- 6) The contactors mentioned above in points 3, 4 and 5 are installed in the distribution cabinet. The mains cables for the radiators should be dimensioned and protected according to DIN VDE 0100.
- 7) The **heat circulating pump** (M13) is connected to the terminals X1/N and **J13/NO 5**.
- 8) The **hot water circulating pump** (M18) is connected to the terminals X1/N and **J13/NO 6**.
- 9) The brine or well pump is connected to the X1/N and **J12/NO 3** terminals.
When using air-to-water heat pumps, **never** connect a **heat circulating pump** to this output.
- 10) The **return flow sensor** (R2) is either directly integrated in brine-to-water and water-to-water heat pumps or is included in the scope of supply as a separate component. The return flow sensor is integrated in air-to-water heat pumps for indoor installation and is connected to the heat pump manager via the control line. Both single-core wires are connected to the terminals X3 (ground) and **J2/B2**.
When implementing air-to-water heat pumps for outdoor installation, the return flow sensor must be connected to the common return flow of the heating system and the hot water system (e.g. immersion sleeve in compact manifold). The heat pump manager is also connected via the following terminals: X3 (ground) and J2/B2.

- 11) The **external sensor** (R1) is connected to the terminals X3 (ground) and **J2/B1**.
- 12) The **hot water sensor** (R3) is installed in the hot water cylinder and is connected to the terminals X3 (ground) and **J2/B3**.
- 13) The heat pump and the heat pump manager are connected to each other (round plug) via coded **control lines** which must be ordered separately in the case of heat pumps installed outdoors. Always connect the single-core wire (No.8) to the terminal **J4-Y1**.

i NOTE

If three-phase pumps are implemented, a power contactor can be controlled via the 230 V output signal of the heat pump manager. Sensor cables can be extended to up to 30 m with 2 x 0.75 mm cables.

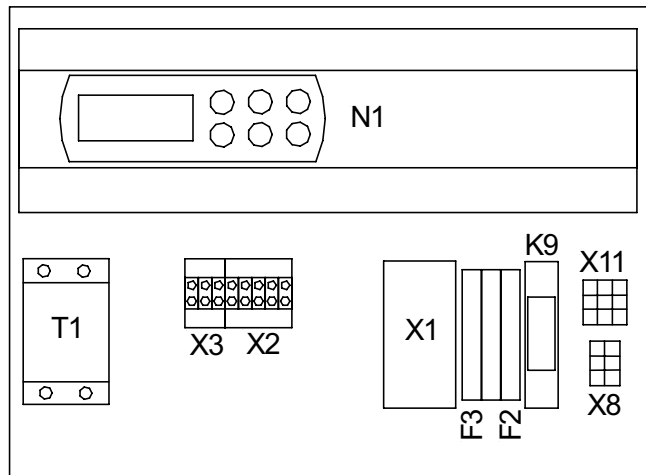

Fig. 4.1: Wall-mounted heat pump manager (heating)

- F2 Load fuses J12-J13 4 A slow-acting
- F3 Load fuses J14-J18 4 A slow-acting
- K9 230 V/ 24 V coupling relay
- N1 Heating controller
- T1 Transformer
- X1 230 V AC terminal strip
- X2 24 V AC terminal strip
- X3 GND(0V) V DC terminal strip
- X8 Extra-low voltage plug connector
- X11 Control plug connector

Legends for Fig. 4.2 on p. 7

- A1 EVS bridge (J5/ID3-EVS to X2) must be inserted if no utility blocking contactor is fitted (contact open = utility block).
- A2 SPR bridge (J5/ID4-SPR to X2) must be removed, if the input is used (input open = HP blocked)
- A3 Bridge (M11 fault). A floating NC contact can be used in place of A3 (e.g. protective motor switch)
- A4 Bridge (M1 fault). A floating NC contact can be used in place of A4 (e.g. protective motor switch)
- B2* Low pressure brine controller
- B3* Hot water thermostat
- B4* Swimming pool water thermostat

- E3** Defrost end pressure switch
 - E9 Electric immersion heater hot water
 - E10* 2nd heat generator (boiler or elect. heating element) selectable via controller
 - F2 Load fuse for plug-in terminals J12 and J13 5 x 20 / 4.0 A slow-acting
 - F3 Load fuse for plug-in terminals J15 to J18 5 x 20 / 4.0 A slow-acting
 - F4** High-pressure switch
 - F5** Low-pressure switch
 - F6** Flow temp. limit thermostat
 - H5* Remote fault indicator lamp
 - J1 Control unit power supply connection (24 V AC / 50 Hz)
 - J2 Connection for hot water sensor, return flow sensor and external sensor
 - J3 Input for HP code and flow sensor via control line plug connector X8
 - J4 0-10 V DC output for controlling the frequency converter, remote fault indicator, and swimming pool circulating pump
 - J5 Connection for hot water thermostat, swimming pool thermostat and utility block functions
 - J6 Connection for the heating circuit 2 sensor and defrost end sensor
 - J7 Connection for "low-pressure brine" alarm message
 - J8 230 V AC input and outputs for controlling the HP Control line plug connector X11
 - J9 Socket not used
 - J10 Socket for connecting the remote control (6-pole)
 - J11 Connection not used
 - J12 to
 - J18 230 V AC - outputs for controlling the system components (pump, mixer, heating element, solenoid valve, boiler)
 - K9 Coupling relay 230 V/24 V for defrost end or flow temperature limit
 - K11* Electron. relay for remote fault indicator
 - K12* Electron. relay for swimming pool water circulating pump
 - K20* Contactor for heat exchanger 2
 - K21* Contactor for electric immersion heater hot water
 - K22* Utility blocking contactor (EBC)
 - K23* Auxiliary relay for SPR
 - K28* External switching to "cooling" operation
 - M1** Compressor 1
 - M2** Ventilator - only for air-to-water heat pumps
 - M3** Compressor 2 - only for systems with two compressors
 - M11* Heat source primary pump (brine or well pump)
 - M13* Heat circulating pump
 - M15* Heat circulating pump for heating circuit 2/3
 - M16* Auxiliary circulating pump
 - M18* Hot water circulating pump
 - M19* Swimming pool water circulating pump
 - M21* Mixer for main circuit or heating circuit 3
 - M22* Mixer for heating circuit 2
 - N1 Control unit
 - N6* Cooling controller
 - N10* Remote control (for WPM 2007 R already used by control panel N14)
 - N11* Relay module
 - R1 External wall sensor
 - R2 Return flow sensor
 - R3* Hot water sensor
 - R5 Sensor for heating circuit 2
 - R9 Flow sensor
 - R12 Defrost end sensor
 - R13 Sensor for heating circuit 3 / renewable sensor
 - T1 230 / 24 V AC / 28 VA safety transformer
 - W1 Control line, 15-pole
 - W1-# Core number of cable W1
 - W1-#8 must always be connected!**
 - X1 Terminal strip - supply connection, N and PE distribution board
 - X2 24 V AC distribution board terminal
 - X3 Distribution board terminal - ground
 - X4 Plug connector terminal
 - X8 Control line plug connector (extra-low voltage)
 - X11 230 V AC control line plug connector
- Abbreviations:**
 MA Mixer "OPEN"
 MZ Mixer "CLOSED"
- *) Components must be supplied by the customer
 ** Components are in the heat pump
- Wired ready for use
 - - - To be connected by the customer as required

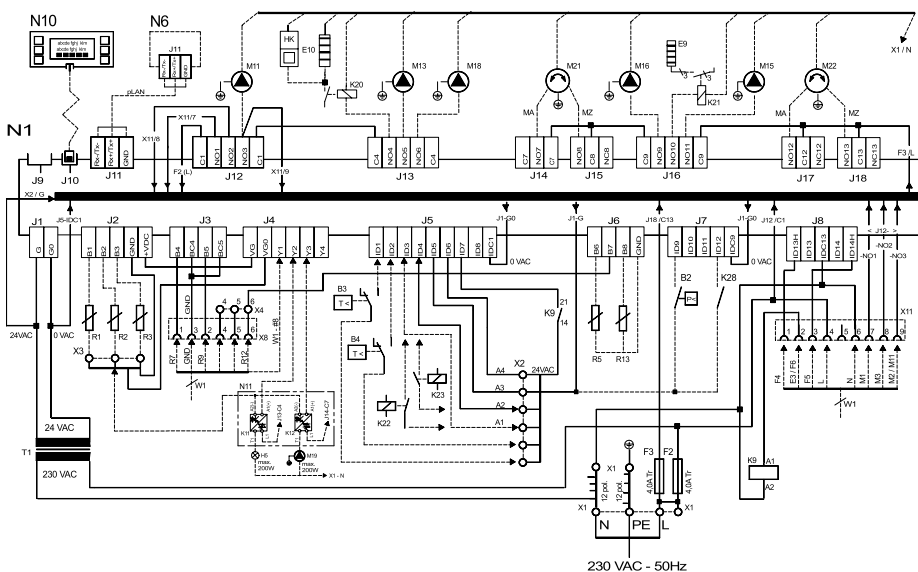

Fig. 4.2: Circuit diagram of the wall-mounted heat pump manager

5 Preconfiguring the Heat Pump Heating System

The preconfiguration informs the controller about which components are connected to the heat pump heating system. Preconfiguration must be carried out before the system-specific settings in order to show or hide menu items (dynamic menus).

The following table shows not only the menu structure and explanations in the right-hand column, but also the

corresponding setting ranges. Values in bold print indicate the factory settings.

The factory settings in the “Preconfiguration” menu correspond to the integration diagram for a mono energy heat pump (normally an air-to-water heat pump) with 1 compressor and a heating circuit without DHW heating using the heat pump.

5.1 Menu

You can access the preconfiguration menu by:

- Simultaneously pressing (approx. 5 seconds) the button combination (ESC) and (MENU).
- Exit the preconfiguration via the button (ESC).

Abbreviations:

HP	Heat pump
AW HP	Air-to-water heat pump
BW HP	Brine-to-water heat pump
WW HP	Water-to-water heat pump

The following presettings must be carried out:

Preconfiguration	Preconfiguration of all system components for dynamic menu structuring	Setting range	Display
Operating mode	Monovalent (heat pump as sole heat generator), mono energy (heat pump and immersion heater), bivalent-parallel (heat pump and boiler), bivalent-alternative (heat pump or boiler), bivalent-renewable (heat pump or renewable heat source)	Monovalent Mono energy Bivalent-parallel Bivalent-alternat. Bivalent-renewable	Bivalent-renewable, with nonreversible HP only
Additional heat exchanger Domestic hot water	Has an additional heat exchanger with supplementary connections for DHW preparation been installed in the heat pump?	Yes No	Reversible HP AW HP
Heating circuit 1	Has the system got an unmixed heating circuit?	Yes No	Always
Heating circuit 2	Has the system got a heating circuit 2 with a controllable mixer?	No Yes	Always
Heating circuit 3	Has the system got a heating circuit 3 with a controllable mixer?	No Yes	Heating circuit 2 Nonreversible HP Nonbivalent system
Cooling function Active	Will the cooling function of the reversible heat pump be used?	Yes No	Reversible HP
Cooling function passive	Is a passive cooling controller connected to the heating controller?	No Yes	BW or WW HP Nonreversible HP
Passive cooling func. System design	Is a 2 or a 4-pipe system used for passive cooling?	2-pipe system 4-pipe system	BW or WW HP Nonreversible HP Passive cooling function
Domestic hot water preparation	Is DHW heating carried out by the heat pump?	No Yes	Always

Preconfiguration	Preconfiguration of all system components for dynamic menu structuring	Setting range	Display
Domestic hot water preparation Request by	Is a sensor or thermostat used to regulate DHW heating?	Sensor Thermostat	Domestic hot water
Domestic hot water preparation Flange heater	Has a flange heater for reheating and thermal disinfection been installed in the hot water cylinder?	No Yes	Domestic hot water Sensors
Swimming pool preparation	Is swimming pool heating carried out by the heat pump?	No Yes	Always
Low-pressure brine Measurement present	Is a pressure switch installed for monitoring the brine pressure?	No Yes	BW HP with integrated controller
Low-pressure brine	In the event that the pressure switch brine is activated, should this be indicated on the display or should the heat pump and primary pump be switched off?	Display Switch-off	BW or WW HP Low-pressure brine

5.2 Coding

Following resumption of the power supply, the controller automatically identifies the type of heat pump connected. A special coding resistance is installed in every heat pump for this purpose according to the following table:

⚠ ATTENTION!

An air-to-water heat pump with defrosting by reverse circulation is only identified if no sensor is connected to input B7. (Flow temperature limit for BW or WW HP)

HP type	Coding resistor	
	Regulation with integrated display	Regulation with removable control panel
Air-to-water heat pump with defrosting by reverse circulation	∞	∞
Brine-to-water or water-to-water HP (display for HP with wall-mounted controller)	0 Ω	0 Ω
Brine-to-water HP (display for HP with integrated controller)	8.2 k Ω	40.2 k Ω
Water-to-water HP (display for HP with integrated controller)	10.0 k Ω	49.9 k Ω
High-temperature air-to-water HP	13.0 k Ω	63.0 k Ω
Reversible air-to-water HP	5.6 k Ω	28.7 k Ω
Reversible brine-to-water HP	3.8 k Ω	19.6 k Ω
Air-to-water HP with hot gas defrosting	2.8 k Ω	14.7 k Ω

i NOTE

Before adjusting the heat pump manager, check the heat pump type code in the "Operating data" menu. Coding is defined when the voltage is recovered. If the message "Coding, HP fault" appears in the display, the (ESC) button must be pushed.

6 Configuring the Heat Pump Heating System

The menus for "Outputs", "Inputs", "Special functions" and "Modem" as well as the extended setting menu can be set at the configuration level. The extended menu level for technicians is

called by simultaneously pressing the button combination (MENU) and (ENTER ↵) (for approx. 5 seconds)

Select the desired menu item with the arrow buttons and confirm with the ENTER button (↵).

6.1 Settings

Depending on the system configuration, the full "Settings" menu contains the following inquiries:

Settings	System-specific parameters	Setting range	Display
Time	Menu for setting the time. An automatic changeover from daylight saving time (summer) to winter time can be selected.	International 24 h display	Always
Operation	Level for setting operating modes		Always
Operating mode	Selects the operating mode It is also possible to make changes directly using the modus button.	Cooling Summer Auto Party Vacation ZWE	Always
Party mode No. of hours	Duration of party mode in hours After the set period has elapsed, the system returns automatically back to automatic operation again.	0 ... 4 ... 72	Always
Vacation mode No. of days	Duration of vacation mode in days After the set period has elapsed, the system returns automatically back to automatic operation again.	0 ... 15 ... 150	Always
Heat pump	Level for setting the heat pump		Always
No. of compressors	This setting is dependent on the HP type. Refer to the installation and operating instructions of the heat pump or the type plate for the relevant number.	1 2	Nonreversible HP
Operating temp. limit	This setting is dependent on the HP type. Refer to the installation and operating instructions of the heat pump for the relevant temperature limit.	-25° C -15° C	Air HP
High press. switch	This setting is dependent on the HP type. If necessary, refer to the installation and operating instructions of the heat pump for the relevant switching mode.	NC contact NO contact	Always
Low pressure	This setting is dependent on the HP type. If necessary, refer to the installation and operating instructions of the heat pump for the relevant switching mode.	NC contact NO contact	Always
2nd heat generator	Settings for the 2nd heat generator to supplement heat pump heating operation in bivalent and mono energy systems		Bivalent or mono energy
HG2 Limit value	The 2nd heat generator is only necessary as of a particular limit temperature depending on the dimensioning of the heat pump system. The 2nd heat generator is not switched on until the temperature sinks below the set limit temperature.	-20° C ... -5° C ... +20° C	Bivalent or mono energy

Settings	System-specific parameters	Setting range	Display
HG2 Operating mode	A variably-regulated (gliding) 2nd heat generator has its own external temperature-guided regulation and can be flowed through with the full volume as required. A constantly-regulated 2nd heat generator is set to a constant temperature. The mixer regulation is active.	Variable (sliding) Constant	Bivalent
HG2 Mixer Runtime	The runtime between the OPEN and CLOSED end positions varies according to the mixer used. The mixer runtime should be adjusted to ensure optimal temperature regulation.	1 min ... 4 min ... 6 min	Bivalent
HG2 Mixer Hysteresis	The mixer hysteresis forms the neutral zone for operation of the 2nd heat generator. If the set temperature plus hysteresis is reached, a Mixer CLOSED signal is generated. If the set temperature minus hysteresis is undershot, a Mixer OPEN signal is generated.	0.5 K ... 2 K	Bivalent
Utility block (EVU)	This setting determines the response of the 2nd heat generator during a utility block (interruption of the supply voltage). Utility (EVU) 1: The 2nd heat generator is only enabled in the B3 bivalence level during the utility block. The immersion heater of mono energy systems is always blocked. Utility (EVU) 2: The 2nd heat generator is enabled during the utility block. Utility (EVU) 3: The 2nd heat generator is enabled during the utility block if the utility 3 limit temperature is also undershot.	Utility1 Utility2 Utility 3	Bivalent
Lim. temp. Utility 3	Limit temperature for enabling the 2nd heat generator when setting Utility (EVU) 3.	-10° C ... 0° C ... +10° C	Bivalent Utility (EVU) 3
HG2 Special program	The special program should be used for old boilers or bivalent systems with main cylinders. It will help to prevent corrosion caused by condensation. The 2nd heat generator remains in operation for a minimum of 30 hours after enabling.	No Yes	Bivalent
HG2 excess temp. Bivalent-renewable	Temperature difference between cylinder (renewable) and flow temperature that must be overshoot if the HP is to be blocked when a heating request is pending	2° C ... 10° C	Bivalent-renewable
HG2 Swimming pool Bivalent-renewable	Parallel buffer tank temperature (renewable) that must be overshoot if the HP is to be blocked when a request for swimming pool water is pending	10° C ... 35° C ... 50° C	Bivalent-renewable Swimming pool
Heating circuit 1	Settings for heating circuit 1		Heating circuit 1
Heating circuit 1 Control by	The following heating regulation options are available for heating circuit 1: * Return temperature regulation based on the external temperature and the set heating curve * Return temperature regulation via a fixed-setpoint (horizontal heating characteristic curve) * Return temperature regulation based on the room temperature in a reference room	External temperature Fixed-setpoint Room temperature	Heating circuit 1 Room temperature: Not bivalent-renewable. Not heating circuit 3 or silent cooling

Settings	System-specific parameters	Setting range	Display
HC1 Heating curve End point (-20 °C)	The heating curve end point should be set according to the design of the heating system. This should be done by entering the maximum return temperature, which is the product of the maximum calculated flow temperature minus the temperature difference in the heating system (spread).	20° C ... 30°C ... 70° C	Heating circuit 1 Regulation according to external temperature
HC1 Fixed-setpoint Return set temp.	Sets the desired return set temperature when fixed-setpoint regulation is selected	15° C ... 40°C ... 60° C	Heating circuit 1 Heating circuit 1 fixed-setpoint
HC1 Reference room Room set temperature	Sets the desired room set temperature and I ratio when room temperature regulation is selected	15.0 °C / 001 ... 20.0 °C ... / ...60 ... 30.0 °C / 999	Heating circuit 1 Heating circuit 1 reference room
HC1 Return flow Minimum temperature	Sets the minimum return temperature when room temperature regulation is selected	15° C ... 20°C ... 30° C	Heating circuit 1 Heating circuit 1 reference room
HC1 Return flow Maximum temperature	Different maximum temperatures are permissible for panel and radiator heating systems. The upper limit of the return set temperature can be set between 25 °C and 70 °C.	25° C ... 50°C ... 70° C	Heating circuit 1
HC1 Hysteresis Return set temp.	The return set temperature hysteresis forms the neutral zone for operation of the heat pump. If the temperature "Return set temperature plus hysteresis" is reached, the heat pump switches itself off. If the temperature "Return set temperature minus hysteresis" is reached, the heat pump switches itself on.	0.5 K ... 2K ... 5 K	Heating circuit 1
HC1 Time program Lower	Settings to lower the heating characteristic curve of heating circuit 1		Heating circuit 1
HC1 Lower Time1: Time2:	Sets the time during which the temperature in heating circuit 1 is to be lowered	00:00 ... 23:59	Heating circuit 1
HC1 Lower Lower value	Sets the temperature value by which the heating characteristic curve of heating circuit 1 is to be lowered when the temperature is lowered	0 K ... 19 K	Heating circuit 1
HC1 Lower MO ... SU	For each day of the week, it is possible to select whether Time1, Time2, no time or both times are to be active when the temperature is lowered. Operations to lower the temperature that exceed a weekday are activated or deactivated at the end of each day accordingly.	N T1 T2 Y	Heating circuit 1
HC1 Time program Raise	Settings to raise the heating characteristic curve of heating circuit 1		Heating circuit 1
HC1 Raise Time1: Time2:	Sets the time during which the temperature in heating circuit 1 is to be raised.	00:00 ... 23:59	Heating circuit 1
HC1 Raise Raise value	Sets the temperature value by which the heating characteristic curve of heating circuit 1 is to be raised.	0 K ... 19 K	Heating circuit 1
HC1 Raise MO ... SU	For each day of the week, it is possible to select whether Time1, Time2, no time or both times are to be active when the temperature is raised. Operations to raise the temperature that exceed a week day are activated or deactivated at the end of each day accordingly.	N T1 T2 Y	Heating circuit 1

Settings	System-specific parameters	Setting range	Display
Heating circuit 2/3	Menu navigation for heating circuit 2 and 3 is identical		Heating circuit 2
Heating circuit 2/3 Control by	The following heating regulation options are available for heating circuit 2/3: * Return temperature regulation based on the external temperature and the set heating curve * Return temperature regulation via a fixed-setpoint (horizontal heating characteristic curve)	External temperature Fixed-setpoint	Heating circuit 2
Heating circuit 2/3 Temperature sensor	Is the sensor for heating circuits 2/3 installed in the flow and return flow? Setting the return flow will result in the calculated set value of heating circuit 2 also being used for heat pump heating requests. Setting the flow means it is only used for mixer control.	Return flow Flow	Heating circuit 2
HC2/3 heating curve End point (-20 °C)	The heating curve end point should be set according to the design of the heating system. This should be done by entering the maximum flow or return temperature depending on the position of the sensor.	20° C ... 30° C ... 70° C	Heating circuit 2 Regulation according to external temperature
HC2/3 Colder Hotter	Parallel shift of the set heating curve for heating circuit 2. By pressing the arrow buttons once, the heating curve is shifted by 1°C upwards (hotter) or downwards (colder).	Indicator bar	Heating circuit 2
HC 2/3 fixed-setpoint Set temp.	Sets the desired return set temperature when fixed-setpoint regulation is selected	15° C ... 40° C ... 60° C	Heating circuit 2 Heating circuit 2 fixed-setpoint
HC2/3 Return flow Maximum value	Different maximum temperatures are permissible for panel and radiator heating systems. The upper limit of the set temperature can be set between 25 °C and 70 °C.	25° C ... 50° C ... 70° C	Heating circuit 2
HC2/3 Mixer Hysteresis	The return set temperature hysteresis forms the neutral zone for operation of the heat pump.	0.5 K ... 2 K	Heating circuit 2
HC2/3 Mixer Runtime	The runtime between the OPEN and CLOSED end positions varies according to the mixer used. The mixer runtime should be adjusted to ensure optimal temperature regulation.	1 min ... 4 min ... 6 min	Heating circuit 2
HC2/3 Time program Lower	Settings to lower the heating characteristic curve of heating circuit 2/3		Heating circuit 2
HC 2/3 lower Time1: Time2:	Sets the time during which the temperature in heating circuit 2/3 is to be lowered.	00:00 ... 23:59	Heating circuit 2
HC 2/3 lower Lower value	Sets the temperature value by which the heating characteristic curve of heating circuit 2/3 is to be lowered when the temperature is lowered	0 K ... 19 K	Heating circuit 2
HC 2/3 lower MO ... SU	For each day of the week, it is possible to select whether Time1, Time2, no time or both times are to be active when the temperature is lowered. Operations to lower the temperature that exceed a weekday are activated or deactivated at the end of each day accordingly.	N T1 T2 Y	Heating circuit 2
HC2/3 Time program Raise	All settings to raise the heating characteristic curve of heating circuit 2/3		Heating circuit 2
HC2/3 Raise Time1: Time2:	Sets the time during which the temperature in heating circuit 2/3 is to be raised.	00:00 ... 23:59	Heating circuit 2

Settings	System-specific parameters	Setting range	Display
HC2/3 Raise Raise value	Sets the temperature value by which the heating characteristic curve of heating circuit 2/3 is to be raised when the temperature is raised.	0 K ... 19 K	Heating circuit 2
HC2/3 Raise MO ... SU	For each day of the week, it is possible to select whether Time1, Time2, no time or both times are to be active when the temperature is raised. Operations to raise the temperature that exceed a week day are activated or deactivated at the end of each day accordingly.	N T1 T2 Y	Heating circuit 2
Cooling	Settings for cooling operation		Cooling function
Cooling Dynamic cooling	Has the system got dynamic cooling (fixed return set temperature)?	No Yes	Cooling function
Dynamic cooling Set value (return)	Sets the desired return set temperature when dynamic cooling is selected	10° C ... 15° C ... 30° C	Cooling function Dyn. cooling
Cooling Silent cooling	Has the system got silent (dew point-controlled) cooling?	Yes No	Cooling function
Silent cooling No. of room stations	Are 1 or 2 room climate control stations connected for silent cooling regulation?	1 2	Cooling function Silent cooling
Silent cooling Set value (room temp)	Sets the room set temperature for silent cooling The actual value is measured by room climate control station 1	15.0° C ... 20.0° C ... 30.0° C	Cooling function Silent cooling
Silent cooling Dew point distance	Rise in the minimum flow temperature calculated from the measured values from the room climate control station during silent cooling. A raised value reduces the risk that condensate will form.	1.5 K ... 2.0 K ... 5.0 K	Cooling function Silent cooling
2nd Chiller	Setting to specify whether a second chiller is to be used in the system.	No Yes	Cooling function
Cooling temperature limit	Setting for the external temperature below which the cooling operation is terminated in the case of rev. brine heat pumps or passive cooling.	-20° C ... 3° C ... 35° C	Cooling function Brine heat pump
Domestic hot water	Sets DHW preparation		Domestic hot water
Domestic hot water Shift 2nd compr.	For heat pumps with 2 compressors, this sets the external temperature below which DHW preparation is carried out with 2 compressors	-30° C ... -25° C ... 35° C (10° C HT)	Domestic hot water 2 Compressors Nonreversible HP
Domestic hot water Hysteresis	The hysteresis of the hot water set temperature forms the neutral zone below which a request for domestic hot water will be issued.	2 K ... 15 K	Domestic hot water Sensors
Domestic hot water Parallel heat - DHW	If the heat pump is operated with an additional heat exchanger, is parallel operation of heating and domestic hot water resulting in higher hot water temperatures being reached desirable?	No Yes	Additional heat exchanger Domestic hot water Sensors
Domestic hot water Max. temp. ≈ Parallel	Sets the desired hot water temperature which is to be reached in parallel heating – hot water operation.	10° C ... 45° C ... 80° C	Parallel heat - DHW Additional HE Domestic hot water Sensors
Domestic hot water Parallel cool - DHW	Is parallel operation of cooling and domestic hot water possible due to the hydraulic isolation of the cooling circuit and the hot water circuit?	No Yes	Domestic hot water Sensors Passive cooling function

Settings	System-specific parameters	Setting range	Display
Domestic hot water Hot water set temp.	Sets the desired hot water temperature	30° C ... 45° C ... 85° C	Domestic hot water Sensors
Domestic hot water Block	Sets the time programs for hot water blocks		Domestic hot water
Hot water block Time1: Time2:	Sets the times in which DHW preparation is blocked	00:00 ... 23:59	Domestic hot water
Hot water block MO ... SU	For each day of the week, it is possible to select whether Time1, Time2, no time or both times are to be active when the temperature is lowered. Operations to lower the temperature that exceed a weekday are activated or deactivated at the end of each day accordingly.	N T1 T2 Y	Heating circuit 3
Therm. Desinfection	To carry out a thermal disinfection, the DHW is heated up once to the desired temperature. The heating period is terminated automatically when the set temperature is reached or after 4 hours at the latest.		Domestic hot water Sensors Bivalent or flange heater
Therm. Desinfection Start:	Sets the start time for the thermal disinfection	00:00 ... 23:59	Domestic hot water Sensors Bivalent or flange heater
Therm. Desinfection Temperature	Sets the desired hot water temperature which is to be reached during thermal disinfection	60° C ... 65° C ... 85° C	Domestic hot water Sensors Bivalent or flange heater
Therm. Desinfection MO ... SU	For each day of the week, it is possible to select whether thermal disinfection is desired at the set start time.	N Y	Domestic hot water Sensors Bivalent or flange heater
Domestic hot water Reset HP maximum	By setting Reset to "Yes", the maximum calculated hot water temperatures in HP operation are reset to a value of 65 °C. The setting is automatically reset to "No".	No Yes	Domestic hot water Sensors
Swimming pool	Sets the preparation of swimming pool water		Swimming pool
Swimming pool	Sets whether swimming pool water preparation is carried out with 1 or 2 compressors	1 Compressors 2 Compressors	Swimming pool 2 Compressors Nonreversible HP
Swimming pool Block	Sets the time programs for blocking swimming pool water preparation		Swimming pool
Swimming pool block Time1: Time2:	Sets the time in which a swimming pool block is to take place	00:00 ... 23:59	Swimming pool
Swimming pool block MO ... SU	For each day of the week, it is possible to select whether Time1, Time2, no time or both times are to be active for a swimming pool block. Blocks that exceed a week day are activated or deactivated at the end of each day accordingly.	N T1 T2 Y	Swimming pool
Plant - Pump control	The output of the auxiliary circulating pump can be configured to allow parallel operation of the auxiliary circulating pump and the heat pump's compressor. Configuration is possible for heating, DHW preparation and swimming pool water preparation. The antifreeze functions are ensured.		Always

Settings	System-specific parameters	Setting range	Display
Auxiliary PUMP for heating	Should the auxiliary pump operate during heating operation?	No Yes	Heating circuit 1
Auxiliary PUMP for cooling	Should the auxiliary pump operate during cooling operation?	No Yes	Active or passive cooling
Auxiliary PUMP DHW	Should the auxiliary pump operate during DHW preparation?	No Yes	Domestic hot water
Auxiliary PUMP for swimming pool	Should the auxiliary pump operate during swimming pool water preparation?	No Yes	Swimming pool
Plant optimization Heat PUMP	Is it desirable that the heat circulating pump switches on and off as required? If optimization is switched off (NO), the heat circulating pump is run in continuous operation.	Yes No	Heating circuit 1
Date Day Day	Year Month Day	Sets the date, year, day, month and week day	Always
Language	The language for menu navigation can be selected from the available languages	DEUTSCH ENGLISH FRANCAIS ITALIANO NEDERLAND PORTUGUES POLSKY SVENSKA SLOVENSKO ESPANOL CESKY	Always

6.2 Outputs

Depending on the system configuration, the “Outputs” Menu shows the “OFF or ON” status display for the following outputs:

Outputs	Display
Compressor 1	Always
Compressor 2	2 Compressors
Four-way valve	Cooling function Air-to-water HP
Ventilator / Primary PUMP	Always
2nd heat generator	Bivalent or mono energy
Mixer OPEN 2nd heat generator	Bivalent
Mixer CLOSED 2nd heat generator	Bivalent
Mixer OPEN Heating circuit 3	Heating circuit 3
Mixer CLOSED Heating circuit 3	Heating circuit 3
Heat PUMP	Always
Heat PUMP Heating circuit 1	Cooling function
Heat PUMP Heating circuit 2	Heating circuit 2
Mixer OPEN Heating circuit 2	Heating circuit 2 or cooling operating with silent cooling only with reversible HP
Mixer CLOSED Heating circuit 2	Heating circuit 2 or cooling operating with silent cooling only with reversible HP
Auxiliary PUMP	Always
Cooling PUMP	Passive cooling function
Switch Room thermostat	Cooling function
Primary PUMP Cooling	Passive cooling function
Reversing valve Cooling	Passive cooling function
Hot water PUMP	Domestic hot water
Flange heater	Domestic hot water Sensors Flange heater
Swimming Pool PUMP	Swimming pool

6.3 Inputs

Depending on the system configuration, the "Inputs" menu shows the "Contact open or closed" status display for the following digital inputs:

Inputs	Status display of all digital inputs	
Low-pressure switch	Contact open means a fault has occurred (setting LP pressure switch NC contact ¹)	Always
High-pressure switch	Contact open means a fault has occurred (setting HP pressure switch NC contact ¹)	Always
Defrost end switch	Contact closed denotes defrost end	Air HP without hot gas defrosting
Flow rate monitoring	Contact open means a fault has occurred (insufficient flow rate)	Water HP
Hot gas thermostat	Contact open means a fault has occurred	Air HP
Flow temperature limit thermostat	Contact open means a fault has occurred	BW or WW HP
Motor prot. compressor	Contact open means a fault has occurred	Always
Motor prot. primary pump	Contact open means a fault has occurred	Always
Utility block (EUV)	Contact open denotes a utility block	Always
Ext. disable contact	Contact open denotes a block	Always
Low-pressure switch brine	Contact closed means a fault has occurred	LP brine
Dew point monitor	Contact open means a fault has occurred	Cooling function Silent cooling
Domestic hot water thermostat	Contact closed means that a request for domestic hot water is pending	Domestic hot water Thermostat
Swimming pool thermostat	Contact closed means a request for swimming pool water is pending	Swimming pool

1. Valid for all heat pumps with a manufacturing date after FD8404. All other heat pumps should be adjusted according to the following table:

Heat pump type	High-pressure switch	Low-pressure switch
LI / LA	NO contact	NO contact
SI / WI	NO contact	NC contact
High-temperature	NO contact	NC contact

Tab. 6.1: Switching mode pressure switch for heat pumps with manufacturing date before FD8404

6.4 Special Functions

Depending on the system configuration, the “Special functions” menu contains the following options for changing the current operating statuses:

⚠ ATTENTION!

Special functions should only be activated by a technician to carry out start-up or an analysis of the heat pump system.

Special functions	Activation of special functions		Display
Compressor switch	By activating the “Compressor switch” function, the compressors can be switched during operation in the case of heat pumps equipped with 2 compressors	No Yes	2 Compressors
Quick start	By activating the “Quick start” function, the heat pump can start up after the safety-related periods have elapsed. A switching cycle block is overridden.	No Yes	Always
Deactiv. operating	By activating the “Lower operating limit deactivate” function, the heat pump can start up after the safety-related periods have elapsed. Periods for optimizing the energy efficiency of heat pump operation are overridden.	No Yes	Brine-to-water HP
Start-up	By activating this function, defrosting is disabled for one hour in the case of air-to-water heat pumps. The 2nd heat generator is enabled. If defrosting is taking place, it will be terminated.	No Yes	Air HP
System control	Function testing of pumps and mixer		Always
System control Primary side	By activating this function, the primary side pumps are switched on constantly for a period of 24 hours. The heat pump remains blocked during this period.	No Yes	Always
System control Secondary side	By activating this function, the secondary side pumps are switched on constantly for a period of 24 hours. The heat pump remains blocked during this period.	No Yes	Always
System control Hot water PUMP	By activating this function, the hot water pump is switched on constantly for a period of 24 hours. The heat pump remains blocked during this period.	No Yes	Always
System control Mixer	By activating this function, the mixers in the system are firstly moved in an OPEN and then in a CLOSED direction for the set mixer runtime	No Yes	Always
Initial heat. prog.	Automatic programme for targeted heat drying of screed floors		Always
Initial heat. prog. Maximum temperature	Sets the maximum return temperature to be reached during initial heating	25° C ... 40° C ... 50° C	Always
Domestic hot water / Swimm. pool active	Selecting this function will permit any request for domestic hot water or swimming pool water during initial heating	No Yes	Always
Initial heating	Activates the initial heating program	No Yes	Always
Standard program Screed drying	Activates the standard program for screed drying	No Yes	Always
Individual program Heating-up period	Sets the duration of the individual steps during the heating-up phase	1 ... 24 ...	Always
Individual program Maintaining time	Sets the maintaining time	120 ... 96 ... 480	Always

Special functions	Activation of special functions		Display
Individual program Heating-down period	Sets the duration of the individual steps during the heating-down phase	1 ... 24... 120	Always
Individual program Heat up diff.temp.	Sets the temperature difference between the two steps in the heating-up phase	1 K ... 5 K ... 10 K	Always
Individual program Heat down diff.temp	Sets the temperature difference between the two steps in the heating-down phase	1 K ... 5 K ... 10 K	Always
Individual program Screed drying	Activates the individual program for screed drying	No Yes	Always
Measure Temperature difference	By activating this function, the difference between flow and return flow is measured at the start of defrosting. If the value is > 12 K, a fault is activated.	No Yes	Air HP
Measure defrost	By activating this function, a 2-hour long block is activated if an expected reduction in the flow temperature does not take place	No Yes	Air HP
Service	After-sales service functions		Always
After-Sales Service Defrost	Displays the time to the next defrosting		Always
After-Sales Service Hot gas defrost	Setting the required defrost temperature for hot gas defrost	2° C ... 6° C... 10° C	Air HP hot gas defrost
Sensor external temperature	Setting for selecting the type of external sensor in use.	NTC-2 NTC-10	Controller without integrated display
Display test	After this function is activated, all of the display segments will be activated for approx. 10 seconds.	No Yes	Always
Special functions (Temperatures heating)	Displays all the temperatures measured in the heating system in compact form		Always
Special functions (Digital outputs)	Displays the statuses of all digital outputs in the heating system in compact form		Always
Special functions (Digital inputs)	Displays the statuses of all digital inputs in the heating system in compact form		Always
Special functions (Analogue values cooling)	Displays all the analogue values measured in the cooling system in compact form		Cooling function
Special functions (Digital values cooling)	Displays all the digital inputs and outputs in the cooling system in compact form		Cooling function
Special functions DHW	Display of all HP max. values for the domestic hot water preparation in compact form		Domestic hot water
Heat/aux. pump overtravel	Setting of the overtravel time for the the heat pump and auxiliary pump.	0 s ... 5 s... 420 s	Always
Performance levels K	Display of the potential performance levels in the cooling operating mode (1-2-3 possible) according to the configuration of the system. Manual switching to the desired performance level is possible.		Active cooling function

6.5 Modem / PC Link

It is necessary to configure the modem in the "Modem" menu. Refer to the installation instructions of the remote diagnosis system used regarding installation regulations. Check all

changes to the factory settings very carefully because an existing connection could be severed.

Modem	Adjusting the interface for remote diagnostics	Setting range	Display
Baud rate	Selects the baud rate with which data is exchanged via the serial interface. Ensure that the same baud rate is set on both sides of the communication system.	19200 9600 4800 2400 1200	Always
Address	An address can be assigned to each connection. This value should remain set to 001 in normal operation.	0 ... 001 ... 199	Always
Protocol	Setting the protocol specifies which type of remote diagnostics are used (local or modem)	Local Remote GSM	Always
Password	The remote diagnostic function can be locked by a password	0 ... 1234... 9999	Always
Phone number	This function is currently not in use		Always
Dialling method	This sets which type of telephone connection is used for remote diagnostics via modem	Tone Pulse	Always
No. of rings before answer	This sets the number of rings after which the controller for remote diagnostics answers	0 ... 1 ... 9	Always
Manual dialling	This function is currently not in use	No Yes	Always

7 Energy-Efficient Operation

If heating operation is carried out on the basis of the external temperature, the heating controller calculates a return set temperature from the set heating characteristic curve and the current external temperature.

The heating curve should be set to the maximum calculated return temperature of the heating system. By using the buttons Hotter (↑) and Colder (↓), the heating curve can be shifted upwards or downwards in parallel according to customer requirements to attain the actually desired room temperatures.

Regulation via return temperature

Regulating a heat pump heating system via the return temperature offers the following advantages:

- 1) Long runtimes for the heat pump with all of the circulated heating volume heated according to need.
- 2) Measuring of disturbance variables in the heating system (e.g. passive solar gain).
- 3) A reduction in the temperature spread at a constant return temperature results in lower flow temperatures and thus in more efficient operation.

i NOTE

The heating curve should be set as high as necessary and as low as possible!

7.1 Setting a Heating Curve on the Basis of the External Temperature

The heating curve must be adjusted - separately for heating circuit 1 and 2 / 3 - to suit the respective building and local conditions so that the desired room temperature is also attained when the external temperatures vary. If the external temperature rises, the return set temperature is lowered, thus ensuring energy-efficient operation of the heating system.

Make selections in the menu “Settings – Heating circuit 1/2/3 – Control by – External temperature”. The desired heating curve can be set in the following menu item “Heating curve – End point”.

- 1) In the menu “Settings- Heating curve end point”, enter the maximum required return temperature at an external temperature of $-20\text{ }^{\circ}\text{C}$. The aim is to attain an average constant room temperature even if the external temperatures vary.

- 2) All heating characteristic curves intersect at an external temperature of $+20\text{ }^{\circ}\text{C}$ and a return temperature of $+20\text{ }^{\circ}\text{C}$. This means that at this operating point no more heat output is required. The indicator bar (buttons Hotter ↑ and Colder ↓) can be used to shift the operating point between $5\text{ }^{\circ}\text{C}$ and $30\text{ }^{\circ}\text{C}$ along the axis marked by a slope. This shifts the entire heating curve by a constant amount of 1 K per indicator bar unit upwards or downwards in parallel. The user can make this setting according to his/her individual temperature requirements.
- 3) Each heating curve is limited in an upward direction by the value set in “Settings – Heating circuit 1/2/3 – Heating curve maximum”. In a downward direction, each heating curve is limited by the value $15\text{ }^{\circ}\text{C}$ (air HP) or $18\text{ }^{\circ}\text{C}$ (brine or water HP).

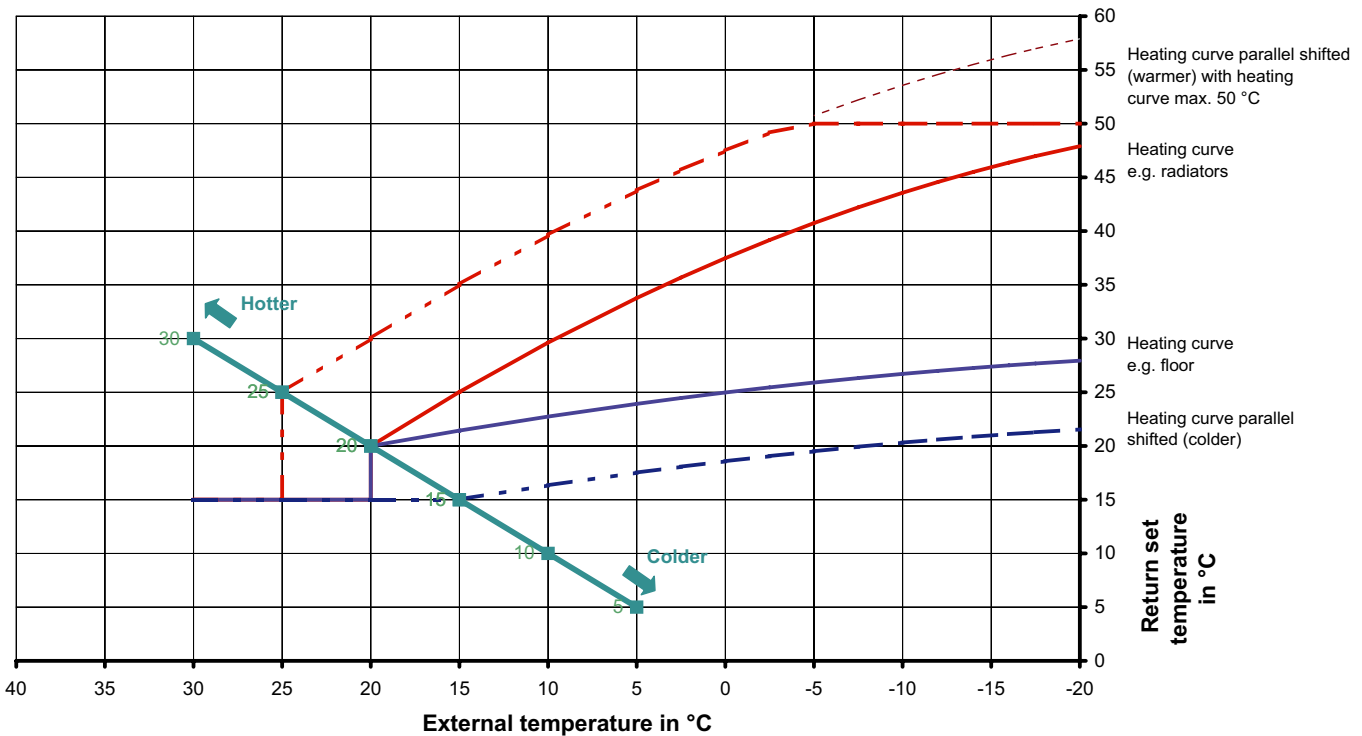

Fig. 7.1: Setting options for the heating curve

7.1.1 Setting examples

	Underfloor heating 35 °C / 28 °C			Radiators 55 °C / 45 °C		
	-12	-14	-16	-12	-14	-16
Standard external air temperature in °C	-12	-14	-16	-12	-14	-16
Required flow temperature (at standard design temperature)	35° C	35° C	35° C	55° C	55° C	55° C
Temperature spread flow/return flow	7° C	7° C	7° C	10° C	10° C	10° C
Required return temperature (at standard design temperature)	28° C	28° C	28° C	45° C	45° C	45° C
Setting for end point of heating curve	30° C	29° C	29° C	48° C	47° C	46° C
	Example 1			Example 2		

A heat distribution system (e.g. underfloor heating) is dimensioned for a maximum flow temperature at a particular standard external temperature. This is dependent on the location of the heat pump and is between -12 and -18 °C in Germany.

The max. return temperature that is set on the heating controller must be entered for an external temperature of -20 °C. This is done by entering the maximum return temperature for the given standard external temperature in Fig. 7.2 on p. 23. The setting at -20 °C can be read using the set of curves.

NOTE

Step 1:

Adjust the heating curve to suit the respective building and local conditions by setting the gradient (heating curve end point).

Step 2:

Set the desired temperature level via a parallel shift of the heating curve upwards or downwards (indicator bar).

Heating curves

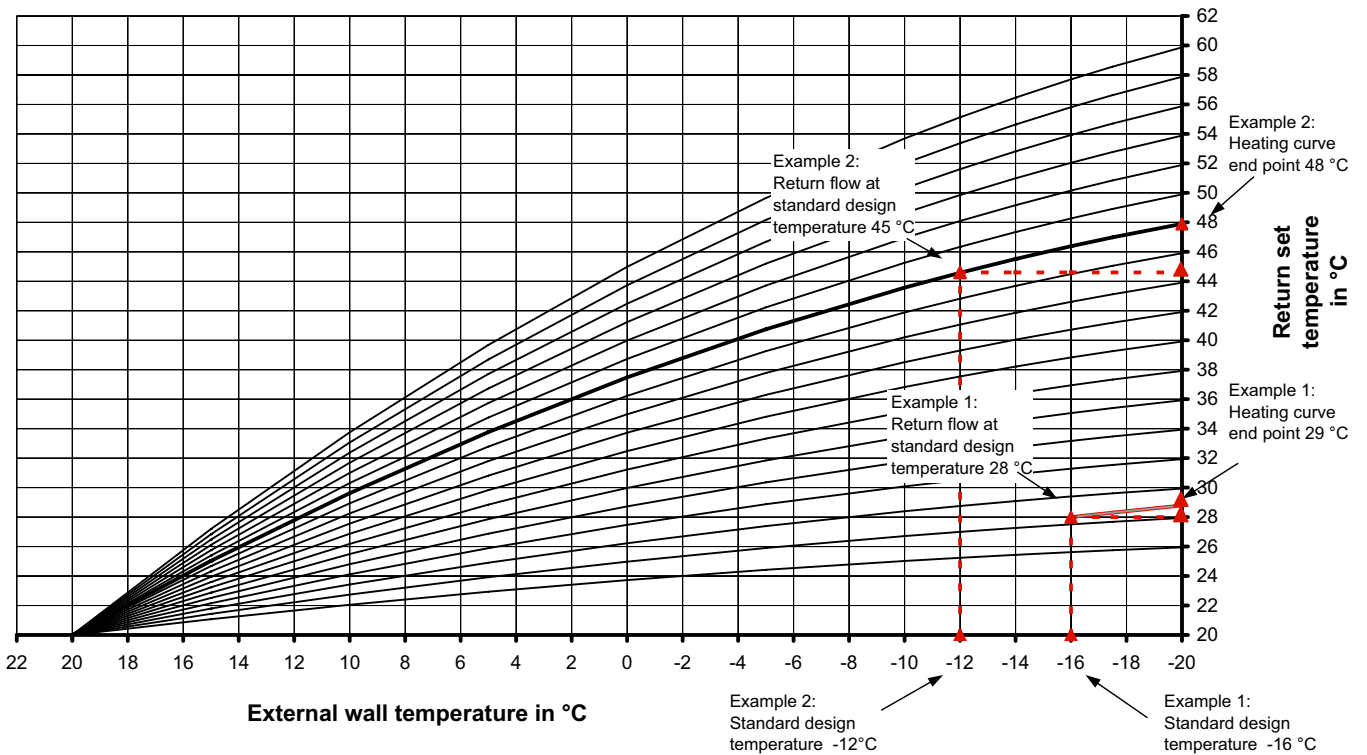

Fig. 7.2: Heating curves to calculate the max. return set temperature

7.1.2 Heating Curve Optimization

There are two setting options for optimizing the heating curve:

- Changing the gradient by means of a higher or lower "Heating curve end point"
- Raising or lowering the entire heating curve by means of the buttons Hotter (↑) and Colder (↓)

If	External temperature		
	Under -7 °C	-7 to +7 °C	Over +7 °C
Too cold	Raise "Heating curve end point" value by 2 °C to 3 °C	Lower Hotter (↑) / Colder (↓) by 1 °C to 2 °C	Lower Hotter (↑) / Colder (↓) by 1 °C to 2 °C and lower "Heating curve end point" value by 2 °C to 3 °C
Too hot	Lower "Heating curve end point" value by 2 °C to 3 °C	Lower Hotter (↑) / Colder (↓) by 1 °C to 2 °C	Lower Hotter (↑) / Colder (↓) by 1 °C to 2 °C and lower "Heating curve end point" value by 2 °C to 3 °C

7.2 Regulation via Room Temperature

Particularly in the case of well insulated houses, open-plan designs or when heating large individual rooms, the return set temperature can be calculated using the room temperature in a reference room.

Make selections in the menu "**Settings – Heating circuit 1 – Control by – Room temperature**".

Automatic controller action

The greater the deviation between the room temperature and the room set temperature, the faster the return set temperature is adjusted.

The response time can be changed by means of the adjustable interval value (I value) if required. The longer the response time, the slower the room set temperature is adjusted.

i NOTE

The entered room set temperature cannot be changed by pressing the buttons Hotter (↑) and Colder (↓).

Prerequisites:

- For systems with silent cooling, the room climate control station is used for room temperature measurement. For all other systems, an additional room sensor (R13) must be connected to the analogue input N1-B8.
- Deactivation of individual room control, if installed, in the reference room.
- Entry of a minimum return set temperature to prevent the building from cooling down if there is internal heat recovery in the reference room.
- Entry of a maximum return set temperature to prevent the building from overheating if the windows are open
- Constant room set temperature with the elimination of as many raising and lowering operations as possible

i NOTE

Activating the room temperature regulation or changing the room set temperature can initially result in the room temperature being exceeded.

7.3 Fixed-Setpoint Regulation / Setting a Horizontal Heating Characteristic Curve

In special cases (e.g. heating a buffer tank to a constant temperature), it is possible to set a characteristic curve which is independent of the external temperature. Make selections in the menu "**Settings – Heating circuit 1/2/3 – Control by – Fixed-setpoint**". The desired return set temperature can be set in the following menu item "**Fixed-setpoint Control – Return set temp.**".

i NOTE

The entered fixed-setpoint cannot be changed by pressing the buttons Hotter (↑) and Colder (↓).

8 Domestic Hot Water Preparation

Hot water cylinders with a sufficient heat exchanger area should be used for DHW preparation. These must be capable of permanently transferring the maximum heat output of the heat pump.

Regulation is carried out using a sensor installed in the hot water cylinder. The sensor is connected to the heat pump manager.

The temperatures attainable in heat-pump-only operation are below the maximum flow temperature of the heat pump.

For higher hot water temperatures, the heat pump manager offers optional control of a flange heater.

Regulation can also be carried out using a thermostat. With this application, selective reheating using a flange heater is not possible.

i NOTE

The additional setting options for heat pumps with an additional heat exchanger installed in the hot gas are described in Chapter *Chap. 12 on p. 32*.

8.1 Basic Heating Using the Heat Pump

A request for domestic hot water is recognised if the current

hot water temperature < (is lower than)
set temperature – hysteresis DHW.

A request for domestic hot water is ended if

hot water temperature > set temperature

i NOTE

DHW heating can be interrupted by defrosting or by the high-pressure safety program.

Menu	Submenu	Set value
Preconfiguration	Domestic hot water preparation	Yes
Preconfiguration	Flange heater	No

Tab. 8.1: Settings for basic heating of domestic hot water (user settings carried out in compliance with the operator's manual)

8.1.1 Attainable hot water temperatures

The maximum hot water temperature which can be attained with heat-pump-only operation is dependent on:

- The heat output of the heat pump
- The heat exchanger surface area in the cylinder and
- The volume flow in relation to the pressure drop and the capacity of the circulating pump.

8.1.2 Hot water temperatures dependent on the heat source

The heat pump manager automatically calculates the maximum possible hot water temperature. It is designated as HPMaximum.

HP Maximum is - along with the influencing factors described in *Chap. 8.1.1 on p. 25* - also dependent on the current temperature of the air, brine or water heat source. To ensure that the maximum possible hot water temperature is always attained, the permissible range of the heat source temperature is divided into temperature ranges. Each range has a specific HPMaximum

Temperature and each HP Maximum is pre-assigned with a default value of 65°C.

If the high-pressure pressure switch activates during DHW preparation with the heat pump, the current heat source temperature is measured and the associated HP Maximum Temperature is calculated as follows:

1 K is deducted from the currently measured hot water temperature and is stored as HP Maximum.

8.2 Reheating with Flange Heater/2nd Heat Generator

Reheating means that the heat pump undertakes DHW preparation until the HPMaximum Temperature is reached. Subsequently, an additional heat generator takes over DHW preparation until the desired set temperature is reached. Reheating is only activated if the desired set temperature is higher than the current HPMaximum Temperature.

Reheating is activated whenever

- The hot water temperature is above the maximum temperature attainable with the heat pump.

If the hot water temperature falls below the Set temperature – hysteresis DHW during reheating, the reheating process is stopped and basic heating is started using the heat pump.

Selection of the respective heat generator for DHW generation is dependent on the operating mode of the heat pump system, the configuration, and the current statuses of the system.

Menu	Submenu	Set value
Preconfiguration	Domestic hot water preparation	Yes
Preconfiguration	Flange heater	Yes

Tab. 8.2: Enables for selective reheating using a flange heater (user settings carried out in compliance with the operator's manual)

8.3 Thermal Disinfection

A start time must be specified for the thermal disinfection. By starting the thermal disinfection, the system will immediately attempt to reach the set temperature. Selection of the DHW generator used for thermal disinfection is dependent on the operating mode of the heat pump system, the configuration, and the current statuses of the system. Thermal disinfection is ended once the set temperature is reached.

To enable the thermal disinfection settings menu, a bivalent heating system and/or flange heater must be set with "Yes" in the preconfiguration.

i NOTE

If the set temperature is not reached within 4 hours, the thermal disinfection is terminated. The set start time can be activated or deactivated separately for each day of the week.

9 Program Description

9.1 Faults

The heat pump is blocked during faults. In the case of bivalent systems, the 2nd heat generator undertakes heating and DHW preparation. In the case of mono energy systems DHW preparation is stopped. The immersion heater maintains the minimum permissible return temperature.

The heat pump manager displays any faults in plain text and, in addition, the button (ESC) blinks red. The heat pump is blocked.

After rectifying the fault, the heat pump can be restarted by pressing the button (ESC). (Switching off the control voltage also acknowledges an existing fault.)

i NOTE

In the case of mono energy systems, by switching to the 2nd heat generator operating mode, the immersion heater can take over heating and the flange heater can take over DHW preparation.

9.2 Limit Temperature (Bivalence Point)

The external temperature at which the heat pump is just able to cover the heat consumption is called the limit temperature or bivalence point. This point marks the transition from heat-pump-only operation to bivalent operation combined with an immersion heater or boiler.

The theoretical bivalence point may deviate from the optimal bivalence point. Particularly during transition periods (cold nights, warm days), it is possible to lower the energy consumption by means of a lower bivalence point in accordance with the wishes and usage of the user. For this purpose, a limit temperature can be set on the heat pump manager in the menu

"**Settings – 2nd heat generator – Limit value**" to enable the 2nd heat generator.

The limit temperature is normally only used in mono energy systems with air-to-water heat pumps or bivalent systems in combination with boilers.

A limit temperature of -5 °C should be aimed for in the case of **mono energy** operation. The limit temperature is calculated from the heat consumption of the building in relation to the external temperature and the heat output curve of the heat pump.

If "**Operating mode Bivalent-alternative**" was set in the preconfiguration, the heat pump is blocked if the external temperature is lower than the set limit temperature.

9.3 Utility Block / Heat Pump Operation Block

Temporary disconnection of the heat pump may be required by utility companies (**Energie-Versorgungs-Unternehmen (EVU)**) as a condition for a favourable electricity tariff. The voltage on terminal ID3 is interrupted during a utility block.

In the case of systems without a utility block, the enclosed bridge must be inserted at the relevant terminal connections.

Set the utility block in the menu "**Settings – 2nd heat generator – Utility block (EVU)**".

In the case of bivalent systems, it is possible to react in different ways to a utility block:

Utility (EVU) 1: Heat pump blocked, the 2nd heat generator is only enabled in Power stage 3 (see *Chap. 9.5 on p. 28*).

Utility (EVU) 2: Heat pump blocked, the 2nd heat generator is enabled if a heating request is pending.

Utility (EVU) 3: Heat pump blocked, the 2nd heat generator is enabled below the adjustable Limit temperature utility 3.

In mono energy and monovalent systems, the 2nd heat generator is normally blocked during a utility block. The setting for the utility block is hidden.

i NOTE

For an external block of heat pump operation which does not automatically reset after a max. of 2 hours the external disable contactor (contact ID4) should be used. If the minimum permissible return temperature is undershot, the heat pump is enabled even when a blocking signal is applied.

9.4 Control of the 2nd Heat Generator

9.4.1 Control of immersion heaters

Supplementary electric heating systems are used in mono energy systems. These are switched on or off depending on the heat consumption if the “Mono energy” operating mode is

selected in the preconfiguration menu and the set limit temperature (see *Chap. 9.2 on p. 26*) is undershot.

9.4.2 Constantly regulated boiler (mixer regulation)

When implementing this type of boiler, the boiler water is always heated to a set temperature (e.g. 70°C) when the command is issued accordingly by the heat pump manager. This temperature must be set so high that domestic hot water preparation can also be carried out using the boiler according to need. Regulation of the mixer is undertaken by the heat pump manager. If required, it

calls for the boiler and adds more hot water until the desired set return temperature or hot water temperature is reached. The boiler is called via the 2nd heat generator output of the heat pump manager and the mode of operation of the 2nd heat generator is coded as being “constant”.

9.4.3 Variably-regulated (gliding) boiler (burner regulation)

In contrast to the constantly-regulated boilers, variably-regulated boilers supply hot water at a temperature which is directly based on the respective external temperature. The three-way reversing valve has no regulatory function. However, it has the task of directing the hot water flow past or through the boiler, depending on the operating mode.

In the case of heat pump only operation, the heating water is directed past the boiler to avoid losses caused by heat

dissipation of the boiler. If the system is equipped with atmospherically controlled burner regulation, the voltage supply for burner regulation should be disconnected in the case of heat pump only operation. The boiler is controlled via the 2nd heat generator output of the heat pump manager, and the mode of operation of the 2nd heat generator is coded as being “variable”. The characteristic curve of the burner regulation is set according to the heat pump manager.

9.4.4 Special program for older boilers and main cylinder systems

If the 2nd heat generator was requested and the so-called special program is activated in the menu “**Settings - 2nd heat generator**”, the 2nd heat generator remains in operation for at least 30 hours. If the heat consumption is reduced during this period, the 2nd heat generator goes into “Active stand-by operation” (2nd heat generator voltage on, but Mixer CLOSED). It is not fully switched off until there has been no request for the 2nd heat generator for a period of 30 hours.

This function can be used in bivalent systems as follows:

- 1) To prevent corrosion damage with older oil or gas boilers due to frequent undershooting of the dew point.
- 2) To ensure that with main cylinder systems, tank charging for the following day is independent of the current heat consumption.

9.4.5 Bivalent-renewable

When integrating a renewable heat source (e.g. solar, wood), this must be given priority over heat pump operation (see *Fig. 2.4 on p. V*). This is done by coding to bivalent-renewable in the preconfiguration. As long as the renewable cylinder is cold, the system responds like a mono energy system.

The sensor for the renewable cylinder is connected to the analogue input N1-B8. The mixer outputs of the bivalence mixer are active.

request. It is not enabled again until the difference between the renewable cylinder and the flow is less than half of the switching value.

i NOTE

Heat pumps which are not equipped with an integrated flow sensor must be retrofitted (N1-B5).

i NOTE

When integrating solar heat sources, adjust the set overtemperature to the maximum value to prevent the heat pump from surging.

Basic function:

The temperature in the renewable cylinder is measured and compared with the flow temperature of the corresponding request (domestic hot water, heating or swimming pool). If the temperature is above the conditions listed below, the heat pump is blocked, the renewable cylinder is used as the 2nd heat generator and the bivalence mixer is activated accordingly.

Block by request for domestic hot water:

If the temperature in the cylinder is 5K higher than the current hot water temperature, the heat pump is blocked by a pending request for domestic hot water. It is not enabled again until the difference between the buffer tank connected in parallel and the domestic hot water is less than 3K.

Block by heating request:

If the temperature in the cylinder is 2-10K higher than the current flow temperature, the heat pump is blocked by a pending heating

Block by request for swimming pool water:

If the temperature in the cylinder is higher than 35 °C (value is adjustable from 10 – 50 °C in the menu Settings - 2nd heat generator - Overtemperature), the heat pump is blocked by a pending request for swimming pool water. It is not enabled again until the temperature in the buffer tank connected in parallel is 5K under the switching temperature.

As soon as one of the three blocks described occurs, the heat pump is blocked, and the following message is displayed: HP

waiting, Block BR. The output of the 2nd heat generator is not activated.

Mixer control:

If there is no block by bivalent-renewable, the mixer is switched to continuously CLOSED.

9.5 Power Regulation

The heat pump manager can define a maximum of 3 power stages, L1, L2 und L3, which it switches depending on the heat consumption. Rising heat consumption causes the next highest power stage to be switched, falling heat consumption the next lowest.

L1: Heat pump operates with one compressor

L2: Heat pump operates with two compressors

9.5.1 Heat pumps with one compressor

Criteria for a switchover:

- From L1 to L3 if the heating controller demands "more heat" for more than 60 minutes and the external temperature simultaneously remains under the limit temperature of the 2nd heat generator for more than 60 minutes.

9.5.2 Heat pumps with two compressors

Criteria for a switchover:

- From L1 to L2 if the heating controller demands "more heat" for more than 25 minutes,
- From L2 to L3 if the heating controller demands "more heat" for more than 60 minutes and the external temperature is simultaneously under the limit temperature for more than 60 minutes.
- From L3 to L2 or L1 if the heating controller demands "less heat" for more than 15 minutes or the limit temperature is overshoot.

If there is a bivalent-renewable block because of domestic hot water or swimming pool, the mixer is switched to continuously OPEN.

If there is a bivalent-renewable block because of heating, mixer regulation is active.

L3: Heat pump operates and 2nd heat generator is active (not with monovalent systems)

- The heat pump manager always starts in power stage L1 after start-up or a power failure.
- The power stages are not redefined during defrosting, preparation of swimming pool water, a request for domestic hot water or a utility block.

- From L3 to L1 if the heating controller demands "less heat" for more than 15 minutes or the limit temperature is exceeded.

- From L2 to L1 if the heating controller demands "less heat" for more than 15 minutes.

In power stage L1, one of the heat pump's compressors is switched on or off according to the "more" or "less" signals from the heating controller. In stage L2, one of the heat pump's compressors operates continuously to cover the base load. The second compressor is switched on or off according to the "more" or "less" signals from the heating controller. In stage L3, both compressors operate continuously to cover the increased base load. The 2nd heat generator is regulated. Only one compressor ever operates during defrosting.

Power stage	Heat pump with one compressor	Heat pump with two compressors
Stage L1	One compressor switching only	One compressor switching only
Stage L2	-	1 compressor base load, 1 compressor switching
Stage L3	One compressor and 2nd heat generator, if required	Both compressors and 2nd heat generator
Defrost	Compressor running	One compressor running
DHW heating	Compressor running	One or two compressors running depending on the external temperature
Swimming pool heating	Compressor running	One or two compressors running depending on the setting

9.5.3 High-temperature air-to-water heat pumps

Only 1 compressor normally operates at external temperatures over 10 °C. If the external temperature is under 10 °C and the flow temperature is higher than 50 °C, both compressors are enabled:

1 compressor is switched on initially followed shortly afterwards by the 2nd compressor. If the request is no longer pending or a block is activated, both compressors are switched off simultaneously.

In respect of the power stage, the high-temperature heat pump responds like a heat pump with 1 compressor in this temperature range independent of the selection in the configuration menu, i.e. there is no power stage 2.

If the conditions for switching to power stage 3 as specified in *Chap. 9.5.1 on p. 28* are fulfilled, the 2nd heat generator is enabled.

9.6 Hysteresis

The so-called hysteresis for the different requests can be set in the “**Settings**” menu. The hysteresis forms a “neutral zone” around the corresponding set temperature. If the current temperature is lower than the reduced set temperature around the hysteresis, the request is then recognised. This request remains pending until the current temperature exceeds the upper limit of the neutral zone. This results in a switching cycle around the set value.

Hysteresis of the return set temperature

A hysteresis can be set around the return set temperature for the heating request.

9.7 Control of Circulating Pumps

By controlling the heat, hot water or swimming pool circulating pumps, it can be determined where the heat generated by the heat pump should flow. Individual processing of different requests enables the heat pump to be always operated with the lowest possible flow temperature. This ensures energy-efficient

If the hysteresis is large, the heat pump will operate longer, whereupon the temperature fluctuations in the return flow are correspondingly large. A smaller hysteresis reduces the compressor runtimes and the temperature fluctuations.

i NOTE

For panel heating with relatively flat characteristic curves, set a hysteresis of approx. 1 K because a hysteresis which is too large can prevent the heat pump from switching on.

9.7.1 Heat circulating pump/antifreeze (frost protection)

Two operating modes are possible for heat circulating pumps which can be set in the “**Settings**” menu.

Heating pump optimization is set to “**No**”: The heat circulating pump always operates, with the exception of DHW heating, swimming pool heating and in the “**Summer**” operating mode.

Heating pump optimization is set to “**Yes**”: The heat circulating pump continues to run for 30 minutes after a power up and after switch-off of the heat pump.

If the heat circulating pump was switched off for more than 40 minutes or the return temperature has dropped below the set value, it is switched on for 7 minutes to supply the return flow

If a switchover is made from heating operation to DHW preparation or swimming pool water preparation, the heat circulating pump continues to run for at least 1 minute.

The heating pump operates continuously at external temperatures lower than 3°C, at return temperatures lower than 15°C and at temperatures lower than 6 °C on the flow sensor of air-to-water heat pumps.

operation. With heat pumps for heating and cooling, additional cold circulating pumps can be controlled (*Chap. 12 on p. 32*).

i NOTE

Pump units with check valves maintain the specified flow direction.

sensor with the representative temperature of the heating circuit again (flushing period).

Independent of the setting, the heat circulating pump always operates in heating or defrost operation and when there is danger of frost. In systems with several heating circuits, the heat circulating pumps 2/3 have the same function.

! ATTENTION!

To ensure that the antifreeze function of the heat pump works properly, the heat pump manager must remain connected to the power supply and the flow must be maintained through the heat pump at all times.

9.7.2 Hot water circulating pump

The hot water circulating pump (DHW loading pump) operates during DHW heating. If a request for domestic hot water is made during heating operation, the heat circulating pump is deactivated and the hot water circulating pump is activated with the heat pump running.

In the case of heat pumps with additional heat exchangers and **Setting – Parallel heat - DHW** set to “**Yes**”, the hot water pump operates parallel to the heating pump during heating operation until the set maximum temperature is reached.

9.7.3 Swimming pool water circulating pump

The swimming pool circulating pump operates while the swimming pool water is being heated. The swimming pool water heating can be interrupted at any time by a request for domestic hot water, defrosting or by raising the heating characteristic curve (e.g. after lowering the temperature at night), but not by a “more” signal from the heating controller. If the request is still pending after the swimming pool water has been heated for 60 minutes, the swimming pool circulating pump is switched off for 7 minutes and the heat circulating pump is switched on to supply the return flow sensor with the representative temperature of the

heating circuit again. If the heating controller generates a “more” signal during these 7 minutes, the request for heating will be processed first.

i NOTE

In the summer operating mode, swimming pool water preparation is not interrupted after 60 minutes by a flushing period.

9.7.4 Auxiliary circulating pump

The output of the auxiliary circulating pump can be configured to allow parallel operation of the auxiliary circulating pump and the heat pump's compressor. Configuration is possible for heating, DHW preparation and swimming pool water preparation. It also operates if the return temperature has fallen below 15 °C, or the

temperature has fallen below 6 °C on the flow sensor of air-to-water heat pumps.

In the summer operating mode, the auxiliary circulating pump operates for 1 minute every 150 hours.

9.7.5 Primary Pump for Heat Source

The primary pump delivers the energy of the heat source to the heat pump.

Type of heat pump	Primary pump
Air-to-water heat pump	Ventilator
Brine-to-water heat pump	Brine circulating pump
Water-to-water heat pump	Well pump

The well water or brine circulating pump always operates if the heat pump is switched off. It starts 1 minute before and switches off 1 minute after the compressor.

In the case of air-to-water heat pumps, the ventilator is switched off during defrosting.

10 Start-Up: Air-to-Water Heat Pumps

When the voltage is recovered, air-to-water heat pumps start with defrosting at external temperatures lower than 14 °C or 10 °C. The return temperature must be at least 18°C to prevent defrosting being terminated by the minimum permissible temperature being undershot on the flow sensor.

By activating the start-up function, the 2nd heat generator is enabled for a period of one hour, defrosting is disabled and the current defrosting process is terminated.

The heating pump operates continuously during start-up and requests for domestic hot water or swimming pool water are overridden.

i NOTE

At low heating water temperatures, heat up the buffer tank first before gradually opening the individual heating circuits.

11 Initial Heating Program (Drying of Screed Flooring)

The screed flooring heating is carried out according to the applicable standards and regulations. However, these have to be adapted to suit the requirements of a heat pump heating system (see *Chap. 11.1 on p. 30*).

The individual programs are activated in the menu "**Special functions - Initial heating prog**").

During heating, the following applies:

- The heating pumps for heating circuits 1 and 2 operate continuously
- Programmed lowering or raising of the temperature are overridden and a fixed hysteresis of ± 0.5 K applies (independent of the configuration in the menu)
- The limit temperature for HG2 is fixed at +35 °C (independent of the configuration in the menu)
- The calculated set temperature applies for all heating circuits

- The mixer of heating circuit 2/3 is switched to continuously OPEN
- In the case of a fault or voltage interruption, only the selected program is interrupted. After the voltage is recovered or the fault is acknowledged, the relevant program step is continued.
- The controller records the data in the HISTORY regarding the initial heating program that was last completed.

i NOTE

If the manufacturer has not made any special requirements, we recommend using the standard program for screed drying (max. return temperature 35-40 °C).

i NOTE

If no button is pushed within 3 minutes following the activation of an initial heating program the display changes every minute. In the bottommost display line, the current heating-up step, the set temperature, completed and required hours are displayed.

11.1 Implementing the Heat Pump Heating System Directive

The directive is based on whole days for which a specified temperature is to be reached or maintained.

If the screed flooring has a high moisture content, the specified temperatures are often not reached within the prescribed period of time. However, for sufficient baking, it is essential that the temperature level is maintained for a definite period.

For this reason, the days described in the standard are implemented as program steps. One program step corresponds

to the combination of the number of days and/or hours and the respective temperature.

i NOTE

Depending on the ratio between the heat output of the heat pump and the living space area to be heated, the specified minimum heating-up period can be exceeded considerably. This is because the required minimum number of hours are not totalled until after the set temperature has been reached.

The relevant standards and directives always refer to the flow temperature of the heating system. Regulation of the heat pump is based primarily on the return temperature.

i NOTE

The max. return temperature must be entered for the initial heating program. This is the sum of the max. flow temperature minus the temperature spread (e.g. 7K).

11.2 Initial Heating According to DIN EN 1264-4

This program is a recognised function test for underfloor heating and is carried out after the prescribed waiting time for screed flooring.

By doing this, any shortcomings in the screed flooring and the underfloor heating will be noted.

- Step 1:** A constant return temperature of 20 °C is to be maintained for 72 hours (3 days).
- Step 2:** The maximum return temperature (adjustable) is to be maintained for 96 hours (4 days).
- Step 3:** The heat pump remains off until the return temperature has fallen below 20 °C.

The period for step 3 is limited to a maximum of 72 hours because the return temperature of 20 °C will probably not be undershot at high external temperatures.

! ATTENTION!

Initial heating is used to check the function of the heated floor. The check must not be carried out any earlier than 21 days after completion of the screed work in the case of a cement floor and 7 days in the case of a calcium sulphate floor.

After completion of the screed flooring, the appropriate waiting time and the initial heating period, determining whether the screed is dry is a prerequisite for fitting the final floor covering.

11.3 Drying of Screed Floors

11.3.1 General information

This program is used to reduce the moisture in the screed flooring to such an extent that the floor covering can be laid.

However, it is still mandatory to measure the moisture content of the floor as it may be necessary to continue the drying-out process.

The directive regarding drying out screed flooring calls for a fixed number of steps with specified temperatures and times. This

sequence can be selected in the menu as “**Screed drying - Standard program**”.

In consultation with your screed flooring contractor, the Standard program should normally be used. It is only necessary to individually adapt the specified sequence in the Standard program if there are any special heating-up requirements. In this case, selections can be made in the menu “**Screed drying - Individual program**”.

11.3.2 Standard program for screed drying

This program consists of 8 steps and is normally suitable for all underfloor heating systems. Before activation, enter the maximum permissible return temperature, e.g. 32 °C.

- Step 1-4:** Heating-up sequences
- Step 5:** Keep
- Step 6-8:** Heating-down sequences

Steps 1 to 4 are heating-up sequences with a duration of 24 hours each. The return set temperature is raised from 20 °C to the maximum return temperature in each step.

Two conditions must be fulfilled to end a program step. The associated set temperature must be reached or overshoot and the 24-hour period must have elapsed. If the temperature is reached before the 24-hour period has elapsed, the heat pump maintains the associated set temperature throughout the remaining period. No evaluation is made of how long this temperature was actually attained.

In Step 5, the maximum return temperature should be maintained for a period of 264 hours.

The periods in which the maximum return temperature was also actually reached are totalled up. The upper limit is open and the lower limit is the Set value - Hysteresis.

This program step is not ended until the totalled time reaches a value of 264 hours.

Steps 6 to 8 are heating-down steps with a duration of 24 hours each. The return set temperature is lowered from the maximum return temperature to 20 °C with every step.

Two conditions must be fulfilled to end a program step. The associated set temperature must be undershot and the 24-hour period must have elapsed. If the temperature is undershot before the 24-hour period has elapsed, the heat pump maintains the associated set temperature throughout the remaining period. However, no evaluation is made of how long this temperature was actually attained.

The period for the heating-down sequences is limited to a maximum of 72 hours because the required return temperature will probably not be undershot at high external temperatures.

For example:

Max. return temperature: 32° C

- Step 1-4:** 20 / 24 / 28 / 32 °C
- Step 5:** Keep
- Step 6-8:** 28 / 24 / 20 °C

11.3.3 Individual program for screed drying

This program allows the following settings:

- **Heat up diff. temp.:**
Starting from the initial temperature of 20 °C up to the set maximum temperature, the set temperature is raised by the set difference with every program step.
The number of steps depend on the following factors.
- **Heating-up period:**
The number of hours can be entered here during which the corresponding set temperature must be reached and maintained (function as described above).

- **Keep period:**
The number of hours can be entered here during which the maximum set temperature must be maintained.
- **Heat down diff. temp.:**
Starting from the set maximum temperature down to the initial value of 20°C, the set temperature is reduced by the set difference with every program step.
The number of steps depend on the following factors.
- **Heating-down period:**
The number of hours can be entered here during which the corresponding set temperature must be reached and should be maintained.

12 Extended Installation Instructions for the Heat Pump Manager (Heating/Cooling)

12.1 Heating and Cooling Controller

The system supports two modes for generating the refrigerating capacity:

- Active cooling with a reversible heat pump
- Passive cooling using a heat exchanger

In order to perform cooling functions, a cooling controller is required in addition to the heat pump controller (heating).

- Reversible heat pumps for active cooling are supplied as standard with a heat pump manager (heating/cooling)
- For passive cooling, the cooling controller is connected to the existing heat pump manager (heating).

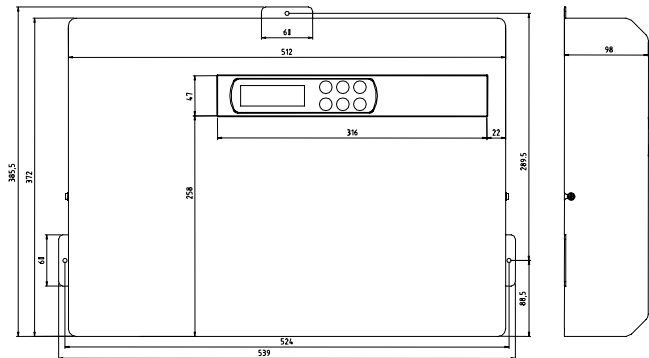

Fig. 12.1: Dimensions of the wall-mounted heat pump manager Heating/cooling

12.1.1 Network operation of heating and cooling controllers and remote control

Both of the controllers (heating and cooling controllers) are connected to the J11 plugs via a three-core connecting cable and are operated as a network. This is done by assigning each controller a network address. The network addresses of the heating and cooling controllers are preassigned.

- Heating controller Network address 01
- Cooling controller Network address 02

These controller addresses are factory default settings. Exception: Heating controller for passive cooling station. See the Passive Cooling Station installation instructions.

The heating and cooling controller software must be compatible in order for the network to work properly.

- Heating software WPM_H_ X Y Z
- Cooling software WPM_K_ X Y Z

The software is compatible if the characters X and Y are identical, e.g.

- WPM_K_H41 is compatible with WPM_H_H45
- WPM_K_H41 is not compatible with WPM_H_H31

Use the “**Operating data network**” menu to check if the cooling controller was identified.

The “**Network heating/cooling**” menu point displays whether the network connection is active.

Set the DIP switches of a connected remote control as follows:



Fig. 12.2: DIP switch settings

12.1.2 Temperature sensor (cooling controller)

All temperature sensors to be connected to the supplementary cooling controllers have the illustrated sensor characteristic curve.

- Room temperature sensor for room climate control station
- Flow sensor for passive cooling
- Return flow sensor for passive cooling

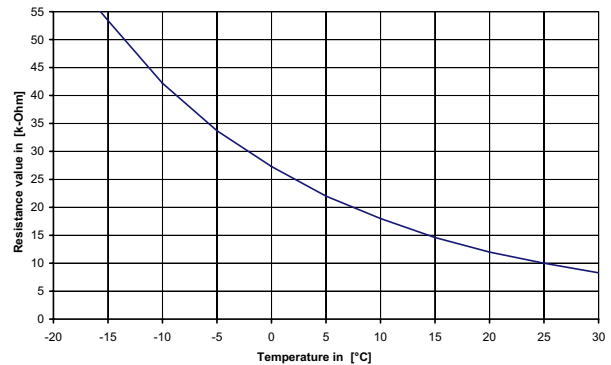

Fig. 12.3: NTC sensor for cooling controller

12.2 Cold Generation by Active Cooling

12.2.1 Heat pumps without additional heat exchangers

Cold is generated actively by reversing the process in the heat pump. The refrigerating cycle is switched from heating to cooling operation using a four-way reversing valve.

i NOTE

The heat pump is blocked for 10 minutes when it is switched from heating to cooling operation. This allows the different pressures in the refrigerating cycle to equalize.

Requests are processed as follows:

- Domestic hot water first
- Cooling first
- Swimming pool

The heat pump operates as in heating operation during DHW or swimming pool water preparation.

12.2.2 Heat Pumps with Additional Heat Exchangers for Waste Heat Recovery

A heat exchanger in the hot gas can use the waste heat generated during cooling for DHW or swimming pool water preparation. The heat exchanger menu item must be set to "YES" to do this.

Requests are processed as follows:

- Cooling first
- Domestic hot water first
- Swimming pool

Adjust the maximum temperature "**Parallel operation heat – Domestic hot water**" in the menu item "**Settings – Domestic**

hot water". If the hot water temperature remains below this limit, the hot water circulating pump will run during cooling operation. Once the maximum set temperature has been reached, the hot water pump is switched off and the swimming pool pump is switched on (independent of the swimming pool thermostat input).

If cooling has not been requested, requests for domestic hot water or the heating requirements of the swimming pool can be processed. However, if cooling has been requested, these functions are cancelled after a maximum continuous runtime of 60 minutes and priority is given to the cooling request.

12.3 Cold Generation via Passive Cooling

In the summer, the ground and the ground water are significantly colder at greater depths than the ambient temperature. A plate heat exchanger installed in the ground water or brine circuit transfers the refrigerating capacity to the heating and cooling circuit. The heat pump compressor is not active and is available for DHW preparation.

Activate parallel operation of cooling and DHW preparation in the menu item "**Settings - Domestic hot water - Parallel cool-DHW**".

i NOTE

Ensure that the special hydraulic installation requirements are fulfilled for the parallel operation of cooling and DHW preparation (see Project Planning and Installation Manual for Heating and Domestic Hot Water)

Passive cooling with borehole heat exchangers

(Bridge A6/ID7 removed)

If cooling is required, an additional primary cooling pump (M12) can be connected to output NO6. The output of the primary circulating pump M11 is only active in heating operation.

Passive cooling with ground water

(Bridge A6/ID7 fitted)

If there is a request for cooling, the primary pump M11 is activated, i.e. the same primary pump is used in both heating and cooling operation (e.g. well pump with water-to-water heat pumps).

12.4 Cooling Program Description

12.4.1 Cooling operating mode

The cooling functions are manually activated as operating mode 6. There is no automatic switching between heating and cooling operation. External switching is possible via the input ID12.

The “**Cooling**” operating mode can only be activated if the cooling function (active or passive) has been enabled in the preconfiguration.

12.4.2 Activation of cooling functions

Special regulatory functions are performed when cooling operation is activated. The cooling controller assumes these cooling functions independently of the remaining regulatory functions.

The cooling functions can fail to activate due to the following reasons:

- The external temperature is below 3 °C (danger of frost)
- The external temperature is below 15 °C (air-to-water heat pumps)

12.4.3 Deactivation of circulating pumps in cooling operation

In the case of a heat pump heating system with **two heating circuits**, the heat circulating pump of heating circuits 1 or 2 can be deactivated in cooling operation.

The heat circulating pump of heating circuit 1 (M14) is not active in cooling operation if silent cooling only is configured.

The heat circulating pump of heating circuit 2 (M15) is not active in cooling operation if silent cooling only is configured.

Passive cooling

The cooling system can be supplied using either the existing heat circulating pump (M13) or an additional cooling circulating pump (M17).

12.4.4 Silent and dynamic cooling

Different system configurations can be implemented according to each integration diagram:

- **Dynamic cooling only** (e.g. fan convectors)
Regulation according to a fixed setpoint. Adjust the return set temperature in the settings menu item.
- **Silent cooling only** (e.g. underfloor heating, wall panel heating or cooled ceilings)
Regulation according to the room temperature. Regulation is based on the temperature in the room where the room climate control station 1 is connected according to the circuit diagram. Set the desired room temperature in the settings menu item.

Switching off the generation of cold

The following limits are provided as safeguards:

- The flow temperature falls below a value of 7 °C
- Activation of the dew point monitor at vulnerable points in the cooling system
- The dew point is reached with silent cooling only

- There is no cooling controller fitted or the connection is broken
- Neither silent or dynamic cooling was selected with “Yes” in the settings

In all these cases, the cooling operating mode will remain active. However, the regulation system responds as in the summer operating mode.

The heat circulating pump can also be used in cooling operation as delivered.

If an additional cooling pump (e.g. 4-pipe system) is used, the heat circulating pump must be deactivated in cooling operation. This is done by inserting a cable bridge A5 between the terminals X2 and ID8 on the passive cooling controller N6.

i NOTE

The cooling circulating pump (M17) operates continuously in the “Cooling” operating mode.

- **Combination of dynamic and silent cooling**

Regulation is carried out separately in two different control circuits.

The dynamic circuit is regulated according to a fixed setpoint (as described for dynamic cooling).

Silent cooling is regulated on the basis of the room temperature (as described for silent cooling) by controlling the mixer for heating circuit 2 (silent heating and cooling circuit).

Make selections in the menu item “**Settings – Cooling**”.

12.5 Regulation of the Room Temperature

Heating systems are normally equipped with an automatic mechanism for separately regulating the room temperature in each room.

The room thermostats measure the current temperature in heating operation. If the current temperature undershoots the set temperature, the thermostats activate the regulating device (e.g. actuator).

In cooling operation, the room thermostats must be either deactivated or replaced with units which are suitable for both heating and cooling.

The room thermostat responds inversely in cooling operation. If the set temperature exceeds the current temperature, the regulating device is activated.

13 Special Accessories

13.1 Remote Control

A remote control adds convenience and is available as a special accessory. Operation and menu navigation are identical to that of the heat pump manager. However, additional functions can be used by means of supplementary pushbuttons (for a detailed description, see remote control instructions). The remote control is connected via a 6-core telephone cable (special accessory) with modular plugs.

13.2 Remote Diagnostic System (FDS)

The remote diagnostic system (**F**ern **D**iagnose **S**ystem - FDS) was developed to enable access to the heat pump manager via PC. In combination with an "Internet-compatible" PC and the separately available hardware packages, the software enables the user settings to be read out and changed as required. The software is programmed to allow a constant exchange of data between the heat pump manager and the PC. Changes are possible both on the heat pump manager and in the program.

The software is started via an Internet browser on the PC and is optimized for the Windows 2000 and XP operating systems.

13.3 Room Climate Control Station

With cooling using panel heating/cooling systems, regulation is carried out according to the room temperature and humidity measured by the room climate control station.

This is done by setting the desired room temperature on the heat pump manager. The minimum possible cooling water temperature is calculated from the room temperature and humidity measured in the reference room. The control response of the cooling system is influenced by the currently measured room temperature and the set room set temperature.

i NOTE

In the case of heating controllers with removable control panels (see *Chap. 3.2.2 on p. 4*), the operating element can also be directly used as a remote control.

Two versions are available:

- Remote diagnostics on-site (e.g. with laptop): **Local Diagnostic System (LDS)**. Direct connection of the PC cable via the LDS hardware package to the heat pump manager (WPM).
- Remote diagnostics via modem connection: **Remote Diagnostic System (RDS)**. RDS is a useful tool for checking the operation of a remotely located plant and for adjusting the user settings on the heat pump manager.



Fig. 13.1: Room climate control station

Anhang / Appendix / Annexes

1 Technische Geräteinformationen / Technical Device Information / Informations techniques sur les appareils	A-II
2 Hydraulische Einbindung / Hydraulic Integration / Intégration hydraulique	A-III
2.1 Einbindungsschema Heizen und Warmwasserbereitung / Integration Diagram for Heating and Domestic Hot Water Preparation / Chauffage et production d'eau chaude	A-III
2.2 Wärmepumpenanlage Heizen/Kühlen mit Zusatzwärmetauscher / Heat Pump System Heating/Cooling with Additional Heat Exchanger / Installation de pompe à chaleur chauffage/rafraîchissement avec échangeur thermique supplémentaire.....	A-VI
3 Stromlaufpläne / Circuit Diagrams / Schémas électriques	A-VII
3.1 Wärmepumpenmanager Heizen / Heat Pump Manager for Heating / Gestionnaire de pompe à chaleur chauffage	A-VII
3.2 Wärmepumpenmanager Heizen und Kühlen / Heat Pump Manager for Heating and Cooling / Gestionnaire de pompe à chaleur chauffage/rafraîchissement.....	A-VIII
3.3 Legende zu Stromlaufplänen / Legend For Circuit Diagrams / Légende des schémas électriques.....	A-X
3.4 Klemmenbelegung Wärmepumpenmanager / Heat pump manager terminal assignation / Affectation broches Gestionnaire de pompe à chaleur	A-XII

1 Technische Geräteinformationen / Technical Device Information / Informations techniques sur les appareils

Netzspannung	Supply voltage	Tension secteur	230 V AC 50 Hz
Spannungsbereich	Voltage range	Plage de tension	195 bis/to/à 253 V AC
Leistungsaufnahme	Power consumption	Puissance absorbée	etwa/approx./env. 50 VA
Schutzart nach EN 60529	Degree of protection according to EN 60529	Degré de protection selon EN 60529	IP 20
Schaltvermögen der Ausgänge	Switching capacity of outputs	Pouvoir de coupure des sorties	max. 2 A (2 A) $\cos(\varphi) = 0,6$ bei/at/à 230 V
Betriebstemperatur	Operating temperature	Température de fonctionnement	0 °C bis/to/à +35 °C
Lagerungstemperatur	Storage temperature	Température d'entreposage	-15 °C bis/to/à +60 °C
Gewicht	Weight	Poids	4100 g
Wirkungsweise	Function	Mode de fonctionnement	Type 1.C
Verschmutzungsgrad	Degree of soiling	Degré de saleté	2
Wärme-/Feuerbeständigkeit	Heat/fire resistance	Résistance à la chaleur et au feu	Kategorie D / Category D / Catégorie D
Temperatur für Kugeldruckprüfung	Temperature for ball pressure test	Température pour l'essai de dureté à la bille	125 °C

2 Hydraulische Einbindung / Hydraulic Integration / Intégration hydraulique

Die Anforderungen an die hydraulische Einbindung einer Wärmepumpen-Heizungsanlage sind den Projektierungsunterlagen zu entnehmen.

The requirements for the hydraulic integration of a heat pump heating system can be found in the project planning documentation.

Pour les exigences en matière d'intégration hydraulique, se référer à la documentation d'études.

2.1 Einbindungsschema Heizen und Warmwasserbereitung / Integration Diagram for Heating and Domestic Hot Water Preparation / Chauffage et production d'eau chaude



Abb. / Fig. / Fig. 2.1: Monovalenter Wärmepumpenbetrieb mit 2.Heizkreisen und Warmwasserbereitung / Monovalent heat pump operation with 2 heating circuits and domestic hot water preparation / Mode monovalent de la pompe à chaleur avec 2 circuits de chauffage et production d'eau chaude

- 1.2 Sole/Wasser-WP
- 2 Wärmepumpenmanager
- 3 Pufferspeicher
- 4 Warmwasserspeicher
- 13 Wärmequelle Erdreich
- M11 Primärpumpe
- M13 Heizungsumwälzpumpe
- M15 Heizungspumpe
- M18 Warmwasserpumpe
- R1 Außentemperaturfühler
- R2 Rücklauffühler
- R3 Warmwasserfühler
- EV Elektroverteilung

- 1.2 Brine-to-water HP
- 2 Heat pump manager
- 3 Buffer tank
- 4 Hot water cylinder
- 13 Heat source ground
- M11 Primary pump
- M13 Heat circulating pump
- M15 Heating pump
- M18 Hot water pump
- R1 External temperature sensor
- R2 Return flow sensor
- R3 Hot water sensor
- EV Electrical distribution system

- 1.2 PAC eau glycolée/eau
- 2 Gestionnaire de pompe à chaleur
- 3 Ballon tampon
- 4 Préparateur d'eau chaude sanitaire
- 13 Source de chaleur terre
- M11 Pompe primaire
- M13 Circulateur de chauffage
- M15 Pompe de chauffage
- M18 Pompe d'eau chaude sanitaire
- R1 Sonde de température extérieure
- R2 Sonde de retour
- R3 Sonde d'eau chaude sanitaire
- EV Distribution électrique

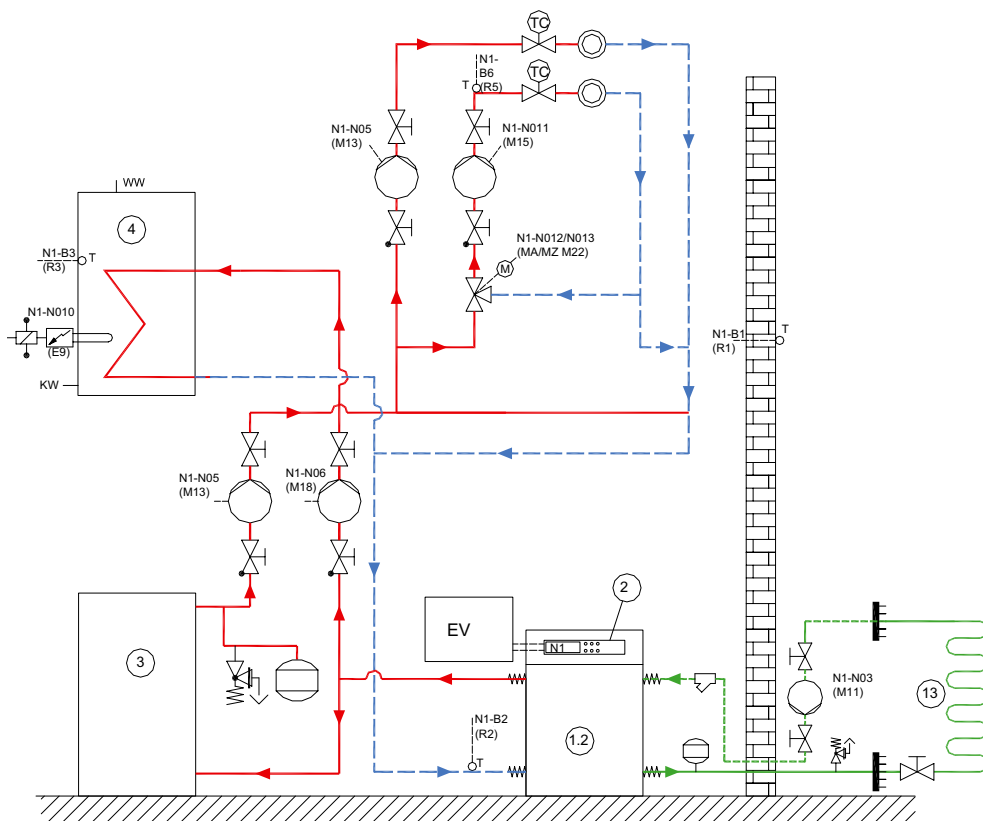

Abb. / Fig. / Fig. 2.2: Monoenergetischer Wärmepumpenbetrieb mit zwei Heizkreisen und Warmwasserbereitung / Mono energy heat pump operation with 2 heating circuits and domestic hot water preparation / Mode mono-énergétique de la pompe à chaleur avec 2 circuits de chauffage et production d'eau chaude

- 1.1 Luft/Wasser-WP
- 2 Wärmepumpenmanager
- 3 Pufferspeicher
- 4 Warmwasserspeicher
- E10.1 Tauchheizkörper
- E9 Flanschheizung
- Warmwasser
- M13 Heizungsumwälzpumpe
- Hauptkreis / 1. Heizkreis
- M15 Heizungsumwälzpumpe
- 2. Heizkreis
- M18 Warmwasserpumpe

- 1.1 Air-to-water HP
- 2 Heat pump manager
- 3 Buffer tank
- 4 Hot water cylinder
- E10.1 Immersion heater
- E9 Flange heater
- Domestic hot water
- M13 Heat circulating pump
- Main circuit / heating circuit 1
- M15 Heat circulating pump
- Heating circuit 2
- M18 Hot water pump

- 1.1 PAC air/eau
- 2 Gestionnaire de pompe à chaleur
- 3 Ballon tampon
- 4 Préparateur d'eau chaude sanitaire
- E10.1 Thermoplongeur
- E9 Résistance électrique chauffante
- Eau chaude sanitaire
- M13 Circulateur de chauffage
- Circuit principal / 1er circuit de chauffage
- M15 Circulateur de chauffage
- 2e circuit de chauffage
- M18 Pompe d'eau chaude sanitaire

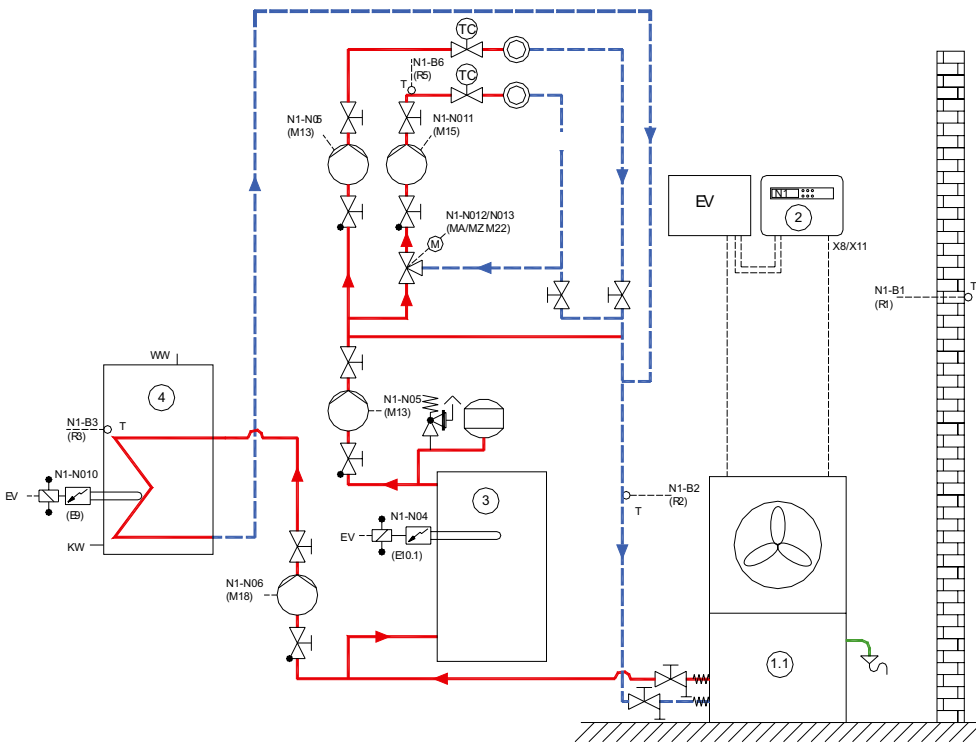

Abb. / Fig. / Fig. 2.3: Bivalenter Wärmepumpenbetrieb mit differenzdrucklosem Verteiler / Bivalent heat pump operation with differential pressureless manifold / Mode bivalent de la pompe à chaleur avec collecteur sans pression différentielle

- 1.1 Wärmepumpe
- 2 Wärmepumpenmanager
- 3 Pufferspeicher
- 7 Heizsystem
- E10.2 Öl-/Gaskessel
- TC Raumtemperaturregler

- 1.1 Heat pump
- 2 Heat pump manager
- 3 Buffer tank
- 7 Heating system
- E10.2 Oil/gas boiler
- TC Room temperature controller

- 1.1 Pompe à chaleur
- 2 Gestionnaire de pompe à chaleur
- 3 Ballon tampon
- 7 Système de chauffage
- E10.2 Chaudière fuel domestique / gaz
- TC Régulateur de température ambiante

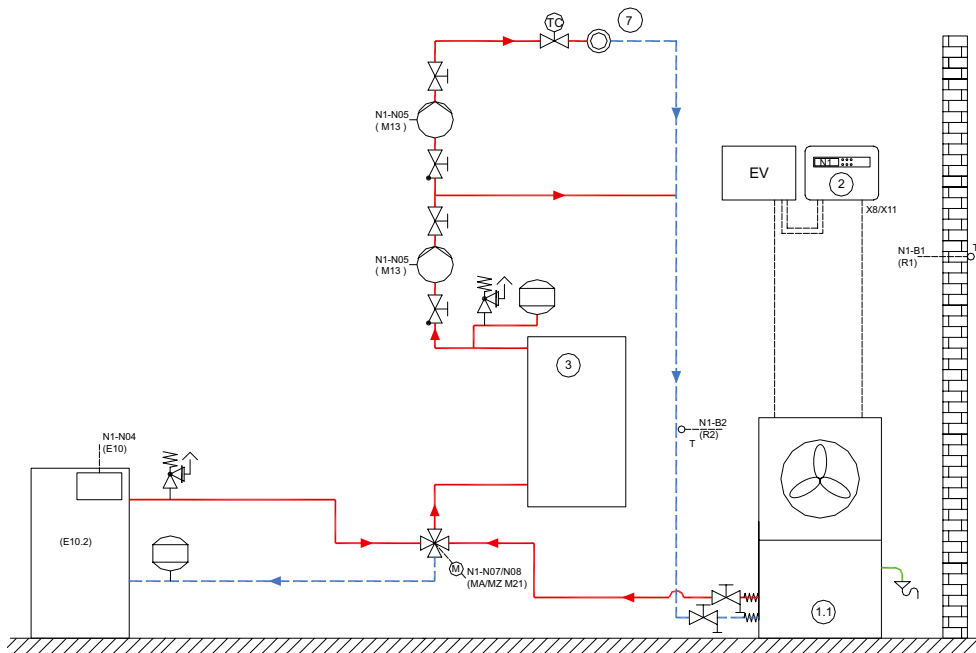

Abb. / Fig. / Fig. 2.4: Einbindungsschema für den bivalent-regenerativen Wärmepumpenbetrieb mit Warmwasserbereitung / Integration diagram for bivalent-renewable heat pump operation with domestic hot water preparation / Schéma d'intégration du mode bivalent-régénératif de la pompe à chaleur avec production d'eau chaude

- 1.1 Wärmepumpe
- 2 Wärmepumpenmanager
- 3 Pufferspeicher
- 3.1 Speicher regenerativ
- R2 Rücklauffühler
- R9 Vorlauffühler
- R13 Fühler regenerativ
- E10.3 Festbrennstoffkessel
- E10.5 Solaranlage
- TC Raumtemperaturregler

- 1.1 Heat pump
- 2 Heat pump manager
- 3 Buffer tank
- 3.1 Renewable cylinder
- R2 Return flow sensor
- R9 Flow sensor
- R13 Renewable sensor
- E10.3 Solid fuel boiler
- E10.5 Solar energy system
- TC Room temperature controller

- 1.1 Pompe à chaleur
- 2 Gestionnaire de pompe à chaleur
- 3 Ballon tampon
- 3.1 Accumulateur régénératif
- R2 Sonde de retour
- R9 Sonde de départ
- R13 Sonde régénérative
- E10.3 Chaudière à combustible solide
- E10.3 Installation solaire
- TC Régulateur de température ambiante

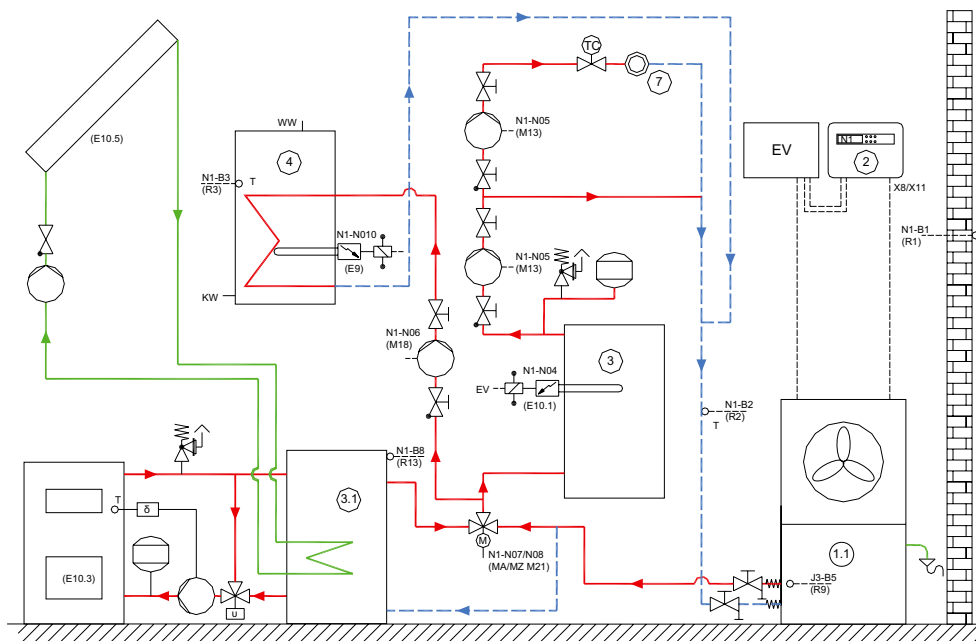
Anhang - Appendix - Annexes

2.2 Wärmepumpenanlage Heizen/Kühlen mit Zusatzwärmetauscher / Heat Pump System Heating/Cooling with Additional Heat Exchanger / Installation de pompe à chaleur chauffage/rafraîchissement avec échangeur thermique supplémentaire



Abb. / Fig. / Fig. 2.5: Einbindungsschema für den monoenergetischen Wärmepumpenbetrieb mit zwei Heiz-/ Kühlkreisen für dynamische oder stille Heizung / Kühlung (aktiv) und effektiver Abwärmennutzung für Warmwasser- und Schwimmbadbereitung. /
Integration diagram for mono energy heat pump operation with two heating/cooling circuits for dynamic or silent heating/cooling (active) and effective waste heat recovery for domestic hot water preparation and swimming pool water preparation. /
Schéma d'intégration pour le mode chauffage mono-énergétique des pompes à chaleur avec deux circuits de chauffage/rafraîchissement pour chauffage/rafraîchissement dynamique ou passif et utilisation effective de la chaleur perdue pour la production d'eau chaude sanitaire et d'eau de piscine.

- 1.4 Reversible Luft/Wasser-Wärmepumpe
- 2 Wärmepumpenmanager Heizen / Kühlen
- 3 Pufferspeicher
- 4 Warmwasserspeicher
- 5 Schwimmbadwärmetauscher
- 6 Warmwasserspeicher
- 7 Heiz-/Kühlsystem

- 1.4 Reversible air-to-water heat pump
- 2 Heat pump manager heating/cooling
- 3 Buffer tank
- 4 Hot water cylinder
- 5 Swimming pool heat exchanger
- 6 Hot water cylinder
- 7 Heating/cooling system

- 1.4 Pompe à chaleur réversible pompe à chaleur
- 2 Gestionnaire de pompe à chaleur chauffage / rafraîchissement
- 3 Ballon tampon
- 4 Préparateur d'eau chaude sanitaire
- 5 Echangeur de chaleur d'eau de piscine
- 6 Préparateur d'eau chaude sanitaire
- 7 Système chauffage/rafraîchissement

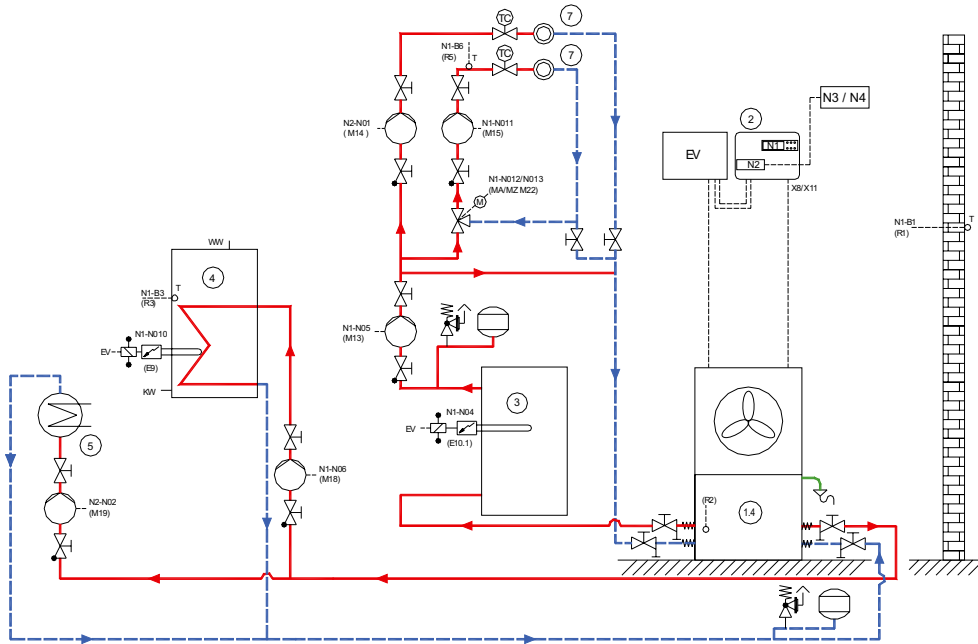
3 Stromlaufpläne / Circuit Diagrams / Schémas électriques

3.1 Wärmepumpenmanager Heizen / Heat Pump Manager for Heating / Gestionnaire de pompe à chaleur chauffage

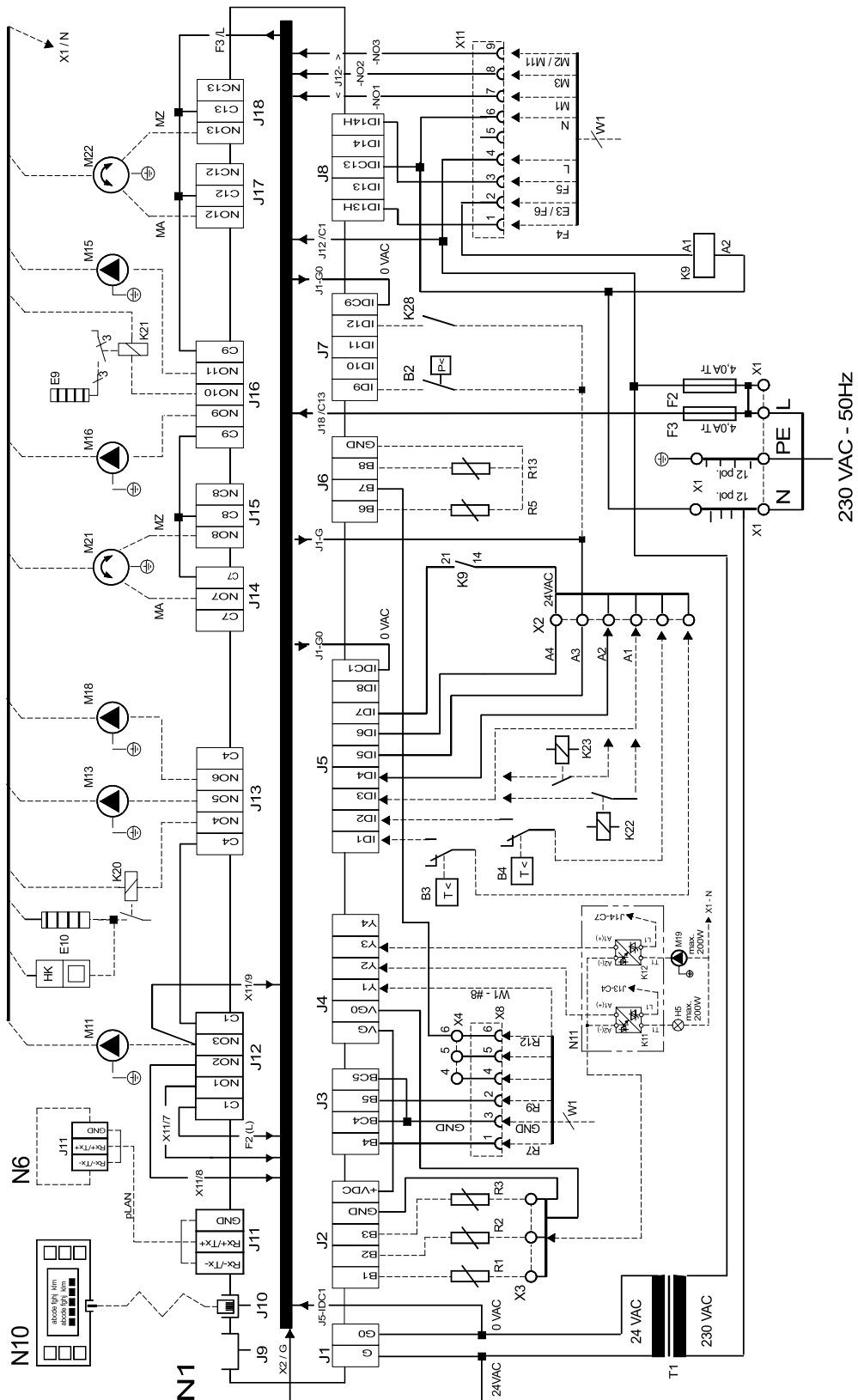

3.2 Wärmepumpenmanager Heizen und Kühlen / Heat Pump Manager for Heating and Cooling / Gestionnaire de pompe à chaleur chauffage/rafraîchissement

Anhang · Appendix · Annexes



Abb. / Fig. / Fig. 3.2: Anschlussplan des wandmontierten Wärmepumpenmanagers WPM 2006 R – N1 /
Circuit diagram for the WPM 2006 R - N1 wall-mounted heat pump manager /
Schéma électrique du gestionnaire de pompe à chaleur mural WPM 2006 R – N1



Abb. / Fig. / Fig. 3.3: Anschlussplan des wandmontierten Wärmepumpenmanagers WPM 2006 R – N2 /
 Circuit diagram for the WPM 2006 R - N2 wall-mounted heat pump manager /
 Schéma électrique du gestionnaire de pompe à chaleur mural WPM 2006 R – N2

3.3 Legende zu Stromlaufplänen / Legend For Circuit Diagrams / Légende des schémas électriques

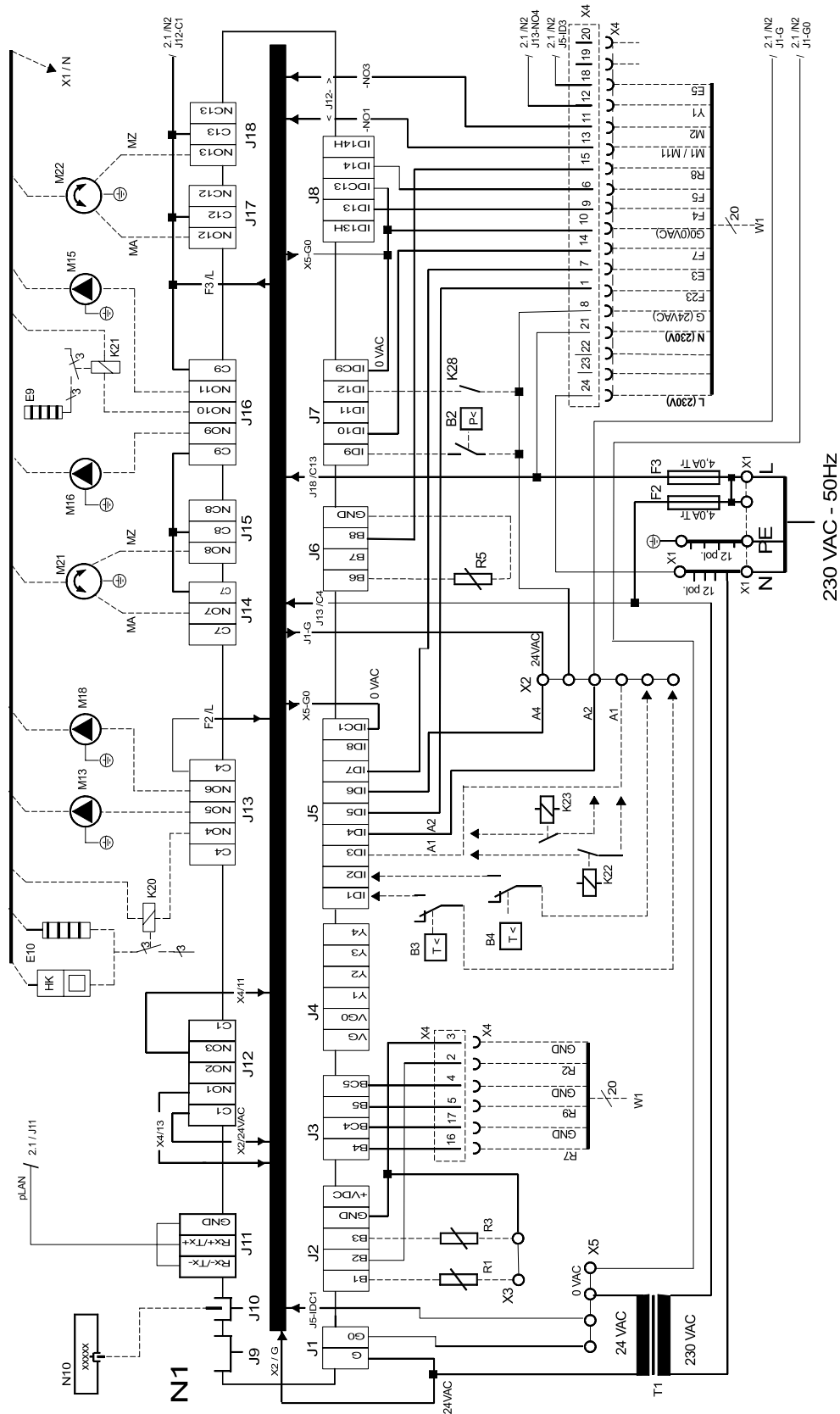
A	Brücken	Bridges	Ponts
A1	Brücke: Energieversorger-Sperre - muss eingelegt werden, wenn die Lastspannung nicht durch den Energieversorger unterbrochen wird	Bridges: Utility company block (Energieversorger-Sperre - EVS) - must be installed if the supply voltage is not interrupted by the energy provider	Pont : Intégrer blocage du fournisseur d'électricité EJP si la tension de charge n'est pas interrompue par le fournisseur d'électricité
A2	Brücke: Sperre Wärmepumpe - Frostschutz gewährleistet	Bridges: Heat pump block - frost protection guaranteed	Pont : Blocage pompe à chaleur - antigel garanti
A3	Brücke bei Wärmepumpen ohne Motorschutzkontakt der Primärpumpe oder des Ventilators	Bridge for heat pumps without motor protection contact of the primary pump or the ventilator	Pont pour pompes à chaleur sans contact protection moteur de la pompe primaire ou du ventilateur
A4	Brücke bei Wärmepumpen ohne Motorschutzkontakt des Verdichters	Bridge for heat pumps without motor protection contact of the compressor	Pont pour pompes à chaleur sans contact protection moteur du compresseur
A5	Brücke für Parallelbetrieb von M13/ M17 m. PKS	Bridge for parallel operation of M13/ M17 with PKS	Pont pour fonctionnement parallèle de M13/M17 m. PKS
A6	Brücke für Parallelbetrieb von M11/ M12	Bridge for parallel operation of M11/ M12	Pont pour fonctionnement parallèle de M11/M12
A7	Brücke Zusatzheizung	Bridge, supplementary heating	Pont chauffage d'appoint
A8	Brücke Warmwasseranforderung	Bridge, request for hot water	Pont demande d'eau chaude
A9	Brücke Fußbodenheizung	Bridge, underfloor heating	Pont chauffage par le sol
B	Hilfsschalter	Auxiliary switch	Commutateur auxiliaire
B2*	Pressostat Niederdruck Sole	Low-pressure brine controller	Pressostat eau glycolée basse pression
B3*	Thermostat Warmwasser	Hot water thermostat	Thermostat d'eau chaude
B4*	Thermostat Schwimmbadwasser	Swimming pool water thermostat	Thermostat d'eau de piscine
E	Heiz-, Kühl- und Hilfsorgane	Heating, cooling and auxiliary units	Dispositifs de chauffage, rafraîchissement et auxiliaires
E3	Abtauende - Pressostat	Defrost end pressure switch	Pressostat fin de dégivrage
E5	Kondensationsdruck - Pressostat	Condensation pressure switch	Pressostat pression condensation
E9	Flaschheizung Warmwasser	Flange heater, hot water	Résistance électrique chauffante ECS
E10*	2. Wärmeerzeuger (Funktion über Regler wählbar)	Heat generator 2 (function selectable via controller)	2. Générateur de chaleur (fonction sélectionnable via régulateur)
E13*	2. Kälteerzeuger	2nd Chiller 2	2. Générateur de froid
F	Sicherheitsorgane	Safety unit	Dispositifs de sécurité
F1	Steuersicherung von N2 / N6	Control fuse of N2 / N6	Fusible de commande de N2 / N6
F2	Lastsicherung für Steckklemmen J12 u. J13 5x20/4,0ATr	Load fuse for plug-in terminals J12 and J13 5 x 20 / 4.0 A slow-acting	Fusible de puissance pour bornes enfichables J12 et J13 5x20 / 4,0 A action retardée
F3	Lastsicherung für Steckklemmen J15 bis J18 5x20/4,0ATr	Load fuse for plug-in terminals J15 to J18 5 x 20 / 4.0 A slow-acting	Fusible de puissance pour bornes enfichables de J15 à J18 5x20 / 4,0 A action retardée
F4	Pressostat - Hochdruck	High-pressure switch	Pressostat haute pression
F5	Pressostat - Niederdruck	Low-pressure switch	Pressostat basse pression
F6	Eingefrierschutz Thermostat	Flow temp. limit thermostat	Thermostat protection antigel
F7	Sicherheitstemperaturwächter	Safety temperature monitor	Contrôleur de température de sécurité
F23	Motorschutz M1 / M11	Motor protection M1 / M11	Protection moteur M1 / M11
H	Leuchten	Lamps	Voyants
H5*	Leuchte Störferrnanzeige	Remote fault indicator lamp	Voyant télédétection de pannes
K	Schütze, Relais, Kontakte	Contactors, relays, contacts	Contacteurs, relais, contacts
K1	Schütz Verdichter 1	Contacteur for compressor 1	Contacteur compresseur 1
K1.1	Anlauf-Schütz Verdichter 1	Start-up contactor for compressor 1	Contacteur démarrage compresseur 1
K1.2	Zeitrelais Verdichter 1	Time relay for compressor 1	Relais temporisé compresseur 1
K2	Schütz (Relais) Ventilator 1	Contacteur (relay) ventilator 1	Contacteur (relais) ventilateur 1
K3	Schütz Verdichter 2	Contacteur for compressor 2	Contacteur compresseur 2
K3.1	Anlauf-Schütz Verdichter 2	Start-up contactor for compressor 2	Contacteur démarrage compresseur 2
K3.2	Zeitrelais Verdichter 2	Time relay for compressor 2	Relais temporisé compresseur 2
K4	Schütz Ventilator 2	Contacteur ventilator 2	Contacteur ventilateur 2
K5	Schütz Primärpumpe - M11	Contacteur, primary pump - M11	Contacteur pompe primaire (M11)
K6	Schütz Primärpumpe 2 - M20	Contacteur, primary pump 2 - M20	Contacteur pompe primaire 2 (M20)
K7	Halbleiterrelais - Abtauung	Semiconductor relay, defrosting	Dégivrage relais statique
K8	Schütz / Relais-Zusatzheizung	Contacteur / relay for supplementary heating	Chauffage d'appoint contacteur / relais

K9	Koppelrelais 230V/24V für Abtauende oder Einfrierschutz	Coupling relay 230 V/24 V for defrost end or flow temperature limit	Relais de couplage 230 V / 24 V pour fin de dégivrage ou protection antigel
K11*	Elektronisches Relais für Störferrnanzeige	Electronic relay for remote fault indicator	Relais électronique pour télé-détection de pannes
K12*	Elektronisches Relais für Schwimmbadwasserumwälzpumpe	Electronic relay for swimming pool water circulating pump	pour circulateur d'eau de piscine
K20*	Schütz 2. Wärmeerzeuger	Contacteur for 2nd heat generator	Contacteur du 2ème générateur de chaleur
K21*	Schütz Flanschheizung Warmwasser	Contacteur, flange heater for hot water	Contacteur résistance électrique chauffante eau chaude sanitaire
K22*	EVU-Sperrschütz (EVS)	Utility blocking contactor (EVS)	Contacteur de blocage du fournisseur d'électricité EJP
K23*	Hilfsrelais für Sperre	Auxiliary relay for block	Relais auxiliaire de blocage
K28*	externe Umschaltung Betriebsart Kühlen	External switching to "cooling" operation	Commutation externe mode opératoire rafraîchissement
M	Motoren	Motors	Moteurs
M1	Verdichter 1	Compressor 1	1er compresseur
M2	Ventilator	Ventilator	Ventilateur
M3	Verdichter 2	Compressor 2	2ème compresseur
M11*	Primärpumpe Wärmequelle	Heat source primary pump	Pompe primaire source de chaleur
M12*	Primärpumpe Kühlen passiv	Primary pump passive cooling	Pompe primaire rafraîchissement passif
M13*	Heizungsumwälzpumpe Hauptkreis	Heat circulating pump for main circuit	Circulateur de chauffage circuit principal
M14*	Heizungsumwälzpumpe 1. Heizkreis bei Kühlung	Heat circulating pump for heating circuit 1 for cooling	Circulateur de chauffage 1er circuit de chauffage à rafraîchissement
M15*	Heizungsumwälzpumpe 2./3. Heizkreis	Heat circulating pump for heating circuit 2/3	Circulateur de chauffage 2ème/3ème circuit de chauffage
M16*	Zusatzumwälzpumpe	Auxiliary circulating pump	Circulateur supplémentaire
M17*	Kühlumwälzpumpe	Cooling circulating pump	Circulateur de rafraîchissement
M18*	Warmwasserumwälzpumpe (Speicherladepumpe)	Hot water circulating pump (load pump)	Circulateur d'eau chaude sanitaire (pompe de suralimentation du ballon)
M19*	Schwimmbadwasserumwälzpumpe	Swimming pool water circulating pump	Circulateur d'eau de piscine
M20*	Primärpumpe 2. Wärmequelle	Primary pump for 2nd heat source	Pompe primaire 2ème source de chaleur
M21*	Mischer bivalent oder 3. Heizkreis	Mixer for bivalent or heating circuit 3	Vanne mélangeuse bivalente ou 3ème circuit de chauffage
M22*	Mischer 2. Heizkreis	Mixer for heating circuit 2	Vanne mélangeuse 2ème circuit de chauffage
N	Regelelemente	Control elements	Eléments de régulation
N1	Heizungsregler	Heating controller	Régulateur de chauffage
N2	Kühlregler (reversible Wärmepumpe)	Cooling controller (reversible heat pump)	Régulateur de rafraîchissement (pompe à chaleur réversible)
N3	Raumklimastation 1	Room climate control station 1	Station de climatisation 1
N4	Raumklimastation 2	Room climate control station 2	Station de climatisation 2
N5	Taupunktwärter	Dew point monitor	Contrôleur du point de rosée
N6	Kühlregler (passive Kühlung)	Cooling controller (passive cooling)	Régulateur de rafraîchissement (rafraîchissement passif)
N9	Raumthermostat (umschaltbar)	Room thermostat (switchable)	Thermostat d'ambiance (commutable)
N10*	Fernbedienung	Remote control	Télécommande
N11*	Relaisbaugruppe	Relay module	Module de relais
N14	Bedienteil für WPM 2007	Control panel for WPM 2007	Commande pour WPM 2007
R	Fühler, Widerstände	Sensor, resistors	Sondes, résistances
R1	Außenfühler	External sensor	Sonde extérieure
R2	Rücklauffühler	Return flow sensor	Sonde de retour
R3*	Warmwasserfühler	Hot water sensor	Sonde d'eau chaude sanitaire
R4	Rücklauffühler Kühlwasser	Return flow sensor for cooling water	Sonde de retour eau froide
R5*	Fühler 2. Heizkreis	Sensor for heating circuit 2	Sonde du 2ème circuit de chauffage
R6	Eingefrierschutzfühler	Flow temoerature limit sensor	Sonde antigel
R7	Kodierwiderstand	Coding resistor	Résistance de codage
R8	Frostschutzfühler Kühlen	Flow sensor, cooling	Sonde antigel rafraîchissement
R9	Vorlauffühler (Frostschutzfühler)	Flow sensor (antifreeze sensor)	Sonde de départ (sonde antigel)
R10.1	Feuchtesensoren von N5 - maximal 5	Humidity sensors for N5 (max. of 5	Capteurs d'humidité de N5 - 5
- 5*	Stück	sensors)	maximum
R11	Vorlauffühler Kühlwasser	Flow sensor for cooling water	Sonde de départ eau de rafraîchissement
R12	Abtauendefühler	Defrost end sensor	Sonde fin dégivrage

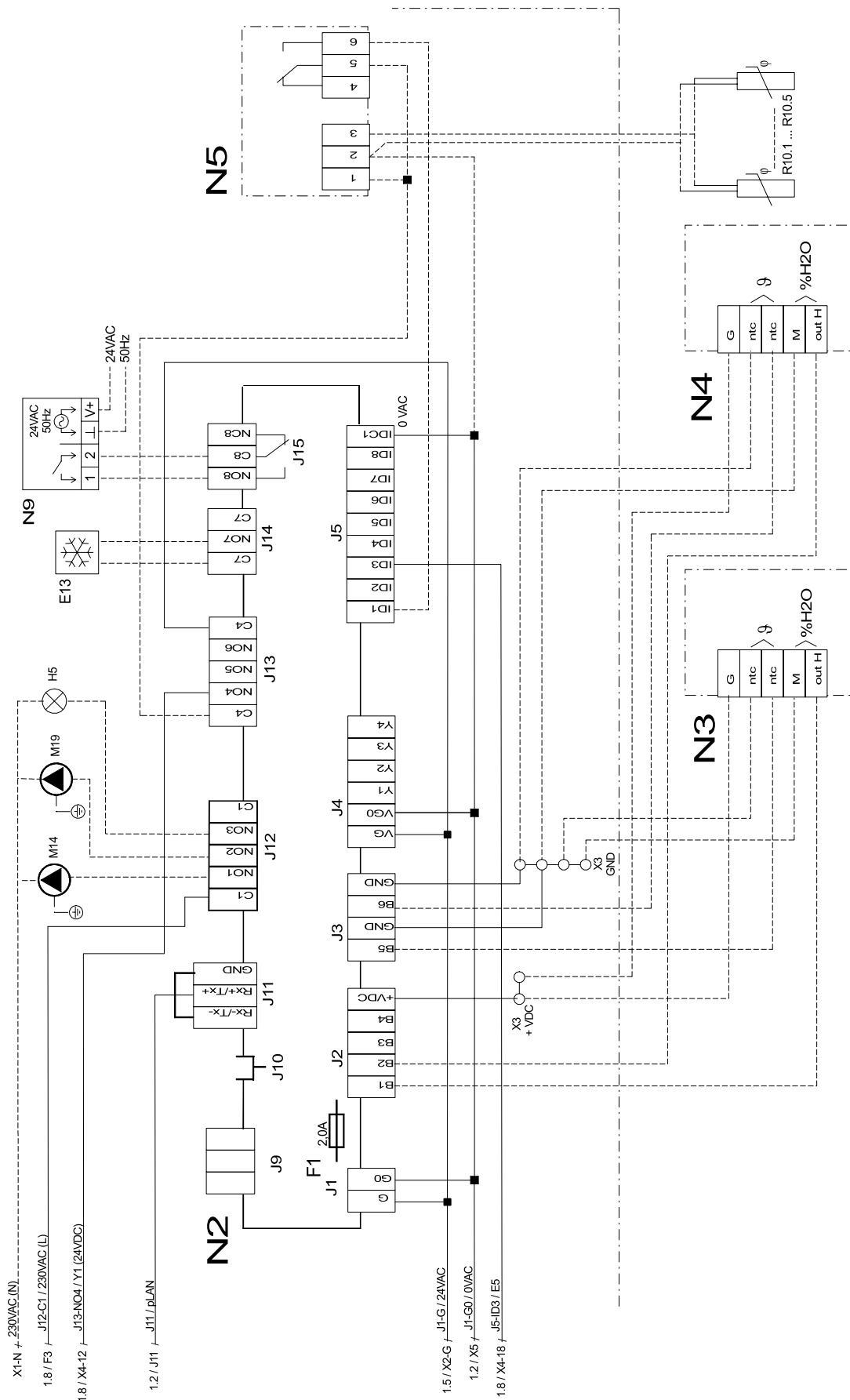
R13	Fühler 3. Heizkreis / Fühler regenerativ	Sensor for heating circuits 2/3 / renewable sensor	Sonde 3ème circuit de chauffage / sonde mode régénératif
R17*	Raumtemperaturfühler	Room temperature sensor	Sonde de température ambiante
R18	Heißgasfühler	Hot gas sensor	Sonde gaz chaud
T	T-Transformator	T-Transformer	Transformateur T
T1	Sicherheitstransformator 230/24V AC	Safety transformer 230/24V AC	Transformateur de sécurité 230/24 V AC
W	Leitungen	Cables	Conduites
W1	Steuerleitung 15polig	Control line, 15-pole	Câble de commande 15 pôles
W1 - #	Adernummer von Leitung W1	Core number of cable W1	Numéro de fil du câble W1
	W1-#8 muss immer angeschlossen werden!	W1-#8 must always be connected!	W1-#8 doit toujours être raccordé !
X	Klemmen, Verteiler, Stecker	Terminals, manifold, plugs	Bornes, collecteurs, connecteurs
X1	Klemmleiste Netzanschluss 230V (L/N/PE)	Supply connection terminal strip 230 V (L/N/PE)	Bornier branchement secteur 230V (L/N/PE)
X2	Kleinspannung	Extra-low voltage	Tension de sécurité
X3	Kleinspannung	Extra-low voltage	Tension de sécurité
X4	Klemme Steckverbinder	Plug connector terminal	Borne connecteur
X5	Verteilerklemme 0V AC	Distribution board terminal 0V AC	Réglette 0V AC
X8	Steckverbinder Steuerleitung (Kleinspannung)	Control line plug connector (extra-low voltage)	Connecteur câble de commande (faible tension)
X11	Steckverbinder Steuerleitung 230V AC	Control line plug connector 230 V AC	Connecteur câble de commande 230V AC
Y	Ventile	Valve	Vannes
Y1	4-Wege-Umschaltventil	Four-way reversing valve	Vanne d'inversion 4 voies
Y5*	3-Wege-Verteilventil	Three-way distribution valve	Vanne de distribution 3 voies
Y6*	2-Wege-Absperrventil	Two-way shutoff valve	Robinet d'arrêt 2 voies
*	optional extern beizustellen	Supplied by the customer, optional	En option à fournir par le client

3.4 Klemmenbelegung Wärmepumpenmanager / Heat pump manager terminal assignation / Affectation broches Gestionnaire de pompe à chaleur

N1	Heizungsregler	Heating controller	Régulateur de chauffage
N1-J1	Stromversorgung (24V AC / 50Hz)	Power supply (24 V AC / 50 Hz)	Alimentation électrique (24V AC / 50Hz)
N1-J2-B1	Außenfühler - R1	External sensor - R1	Sonde extérieure R1
N1-J2-B2	Rücklauffühler - R2	Return flow sensor - R2	Sonde de retour R2
N1-J2-B3	Warmwasserfühler - R3	Hot water sensor - R3	Sonde d'eau chaude sanitaire R3
N1-J3-B4	Kodierung - R7	Coding - R7	Codage R7
N1-J3-B5	Vorlauf- bzw. Frostschutzfühler Heizen - R9	Flow sensor or antifreeze sensor heating - R9	Sonde de départ ou sonde antigel chauffage R9
N1-J4-Y1	Abtauung	Defrosting	Dégivrage
N1-J4-Y2	Leuchte Störferrnanzeige - H5 über K11	Fault indicator lamp - H5 via K11	Voyant télédétection de pannes - H5 via K11
N1-J4-Y3	Schwimmbadwasserumwälzpumpe - M19 über K12	Swimming pool water circulating pump - M19 via K12	Circulateur d'eau de piscine - M19 via K12
N1-J5-ID1	Thermostat Warmwasser - B3	Hot water thermostat - B3	Thermostat eau chaude B3
N1-J5-ID2	Thermostat Schwimmbadwasser - B4	Swimming pool water thermostat - B4	Thermostat eau de piscine B4
N1-J5-ID3	Energieversorgersperre	Utility company block	Blocage du fournisseur d'électricité
N1-J5-ID4	Sperre	Block	Blocage
N1-J5-ID5	Störung Lüfter / Primärpumpe - M2 / M11	Fan fault / primary pump - M2 / M11	Défaut ventilateur / pompe primaire M2 / M11
N1-J5-ID6	Störung Verdichter - M1 / M3	Compressor fault - M1 / M3	Défaut compresseur M1 / M3
N1-J5-ID7	Abtauende - Pressostat - E3; Eingefrierschutz - Pressostat - F6	Defrost end pressure switch - E3; Flow temp. limit pressure switch - F6	Pressostat fin de dégivrage E3; pressostat protection antigel F6
N1-J6-B6	Fühler 2. Heizkreis - R5 und Abtauendefühler	Sensor for heating circuit 2 - R5 and defrost end sensor	Sonde 2ème circuit de chauffage - R5 et sonde de fin de dégivrage
N1-J6-B7	Eingefrierschutzfühler - R6; Abtauendefühler - R12	Flow temperature limit sensor - R6; defrost end sensor - R12	Sonde antigel R6; sonde fin de dégivrage R12
N1-J6-B8	Frostschutzfühler Kühlen - R8; Fühler 3. Heizkreis / Fühler regenerativ - R13	Flow sensor, cooling - R8; sensor for heating circuit 3 / renewable sensor - R13	Sonde antigel rafraîchissement R8; sonde 3ème circuit de chauffage / sonde régénératif R13

N1-J7-ID9	Pressostat Niederdruck-Sole - B2	Low pressure brine controller - B2	Pressostat eau glycolée basse pression B2
N1-J7-ID10	Heißgasthermostat - F7	Hot gas thermostat - F7	Thermostat gaz chaud F7
N1-J7-ID11	Umschaltung Protokoll TAE	Switching protocol TAE	Commutation protocole TAE
N1-J7-ID12	externe Umschaltung Betriebsart Kühlen - K28	External switching to "cooling" operation - K28	Commutation externe mode opérateur rafraîchissement K28
N1-J8-ID13H	Pressostat Hochdruck - 230V AC - F4	High-pressure switch - 230 V AC - F4	Pressostat haute pression - 230V AC - F4
N1-J8-ID13	Pressostat Hochdruck - 24V AC - F4	High-pressure switch - 24 V AC - F4	Pressostat haute pression - 24V AC - F4
N1-J8-ID14	Pressostat Niederdruck - 24V AC - F5	Low-pressure switch - 24 V AC - F5	Pressostat basse pression - 24V AC - F5
N1-J8-ID14H	Pressostat Niederdruck - 230V AC - F5	Low-pressure switch - 230 V AC - F5	Pressostat basse pression - 230V AC - F5
N1-J10	Fernbedienung - N10 / Bedienteil - N14	Remote control - N10 / control panel - N14	Télécommande - N10 / élément de commande - N14
N1-J11	pLAN - Anschluss	Connection for pLAN	Connexion pLAN
N1-J12-NO1	Verdichter 1 - M1	Compressor 1 - M1	Compresseur 1 M1
N1-J13-NO2	Verdichter 2 - M3	Compressor 2 - M3	Compresseur 2 - M3
N1-J13-NO3	Primärpumpe - M11 / Ventilator - M2	Primary pump - M11 / ventilator - M2	Pompe primaire - M11 / Ventilateur - M2
N1-J13-NO4	2. Wärmeerzeuger (E10)	2. Heat generator (E10)	2. Générateur de chaleur (E10)
N1-J13-NO5	Heizungsumwälzpumpe - M13	Heat circulating pump - M13	Circulateur de chauffage M13
N1-J13-NO6	Warmwasserumwälzpumpe - M18	Hot water circulating pump - M18	Circulateur d'eau chaude sanitaire M18
N1-J14-NO7	Mischer 1. Heizkreis Auf - M14	Mixer open - heating circuit 1 - M14	Vanne mélangeuse ouverte 1er circuit de chauffage M14
N1-J15-NO8	Mischer 1. Heizkreis Zu - M14	Mixer closed - heating circuit 1 - M14	Vanne mélangeuse fermée 1er circuit de chauffage M14
N1-J16-NO9	Zusatzumwälzpumpe - M16	Auxiliary circulating pump - M16	Circulateur supplémentaire M16
N1-J16-NO10	Flanschheizung Warmwasser - E9	Flange heater for hot water - E9	Résistance électrique chauffante eau chaude E9
N1-J16-NO11	Heizungsumwälzpumpe 2./3. Heizkreis - M15	Heat circulating pump for heating circuit 2/3 - M15	Circulateur de chauffage 2ème/3ème circuit de chauffage M15
N1-J17-NO12	Mischer 2. Heizkreis Auf - M22	Mixer open - heating circuit 2 - M22	Vanne mélangeuse ouverte 2ème circ. chauff. M22
N1-J18-NO13	Mischer 2. Heizkreis Zu - M22	Mixer closed - heating circuit 2 - M22	Vanne mélangeuse fermée 2ème circ. chauff. M22
N2 (N6)	Kühlregler	Cooling controller	Régulateur de rafraîchissement
N2-J1	Stromversorgung (24VAC / 50Hz)	Power supply (24 V AC / 50 Hz)	Alimentation électrique (24 V AC / 50 Hz)
N2-J2-B1	Feuchte Raumklimastation - N3	Humidity room climate control station - N3	Humidité station de climatisation N3
N2-J2-B2	Feuchte Raumklimastation - N4	Humidity room climate control station - N4	Humidité station de climatisation N4
N2-J2-B3	Vorlauffühler Kühlwasser - R11 / Heißgasfühler - R18	Flow sensor for cooling water - R11 / hot gas sensor - R18	Sonde de départ eau froide - R11 / sonde gaz chaud - R18
N2-J2-B4	Rücklauffühler Kühlwasser - R4	Return flow sensor for cooling water - R4	Sonde de retour eau froide - R4
N2-J3-B5	Temperatur Raumklimastation - N3	Temperature room climate control station - N3	Température station de climatisation N3
N2-J3-B6	Temperatur Raumklimastation - N4	Temperature room climate control station - N4	Température station de climatisation N4
N2-J5-ID1	Taupunktwärter - N5	Dew point monitor - N5	Contrôleur du point de rosée N5
N2-J5-ID3	Pressostat Kondensationsdruck - E5	Condensation pressure switch - E5	Pressostat pression de condensation E5
N2-J11	pLAN - Anschluss	Connection for pLAN	Connexion pLAN
N2-J12-NO1	Heizungsumwälzpumpe 1. Heizkreis - M14	Heat circulating pump of heating circuit 1 - M14	Circulateur de chauffage 1er circuit de chauffage (M14)
N2-J12-NO2	Schwimmbadwasserumwälzpumpe - M19	Swimming pool water circulating pump - M19	Circulateur d'eau de piscine M19
N2-J12-NO3	Störferrnanzeige - H5	Fault indicator lamp - H5	Téledétection de pannes H5
N2-J13-NO4	4-Wege-Umschaltventil	Four-way reversing valve	Vanne d'inversion 4 voies
N2-J14-NO7	2. Kälteerzeuger	2nd Chiller 2	2. Générateur de froid
N2-J15-NO8	Raumthermostat (umschaltbar) - N9	Room thermostat (switchable) - N9	Thermostat d'ambiance (commutable) N9
*	optional extern beizustellen	Supplied by the customer, optional	En option à fournir par le client

i HINWEIS

Relaisbaugruppe:

Die Anbindung von Störferrnanzeige und Schwimmbadpumpe erfolgt beim WPM 2006 plus mit der als Sonderzubehör erhältlichen Relaisbaugruppe RBG WPM.

i REMARQUE

Module de relais :

Le raccordement de la télédétection de pannes et de la pompe de piscine s'effectue, pour le WPM 2006 plus, via le module de relais RBG WPM disponible comme accessoire spécial.

i NOTE

Relay module:

With the WPM 2006 plus, the remote fault indicator and the swimming pool pump are connected via the RBG WPM relay module which is available as a special accessory.

4 Diagnose Störungen - Alarm / Troubleshooting - Alarm / Diagnostic écran perturbations - alarmes

Display	Erklärung / Explanation / Explication	Maßnahmen / Measures / Mesures à prendre
Untere Einsatzgrenze Niederdruck bei Sole- und Wasser/Wasser-WP	Die Wärmepumpe wurde durch Erreichen der unteren Einsatzgrenze ausgeschaltet bzw. Wärmequelle liefert zu wenig Energie	<ul style="list-style-type: none"> ■ Sieb im Schmutzfänger reinigen. ■ Wärmequellenanlage entlüften ■ Sole bzw. Wasserdurchsatz prüfen
Lower operating lim. Low pressure for brine-to-water and water-to-water HP	The heat pump is switched off when the lower operating limit has been reached and/or the heat source delivers insufficient energy	<ul style="list-style-type: none"> ■ Clean the dirt trap filter ■ De-aerate the heat source system ■ Check brine or water flow
Seuil inférieur d'utilisation Basse pression pour PAC eau glyc./eau et eau/eau	La pompe à chaleur a été mise hors service car la limite inférieure d'utilisation a été atteinte ou la source de chaleur fournit trop peu d'énergie.	<ul style="list-style-type: none"> ■ Nettoyer le filtre dans le collecteur d'impuretés. ■ Purger l'installation source de chaleur ■ Contrôler l'eau glycolée ou le débit d'eau
Niederdruck bei Luft/Wasser-WP		<ul style="list-style-type: none"> ■ Verdampfer vereist oder Systemtemperaturen zu gering (< 18 °C).
Low pressure in the air-to-water HP		<ul style="list-style-type: none"> ■ Evaporator iced or the system temperatures are too low (< 18 °C).
Basse pression dans PAC air/eau		<ul style="list-style-type: none"> ■ Evaporateur givré ou températures du système trop faibles (< 18 °C).
Hochdruckabschaltung	Die Wärmepumpe wurde durch Erreichen der maximalen Vorlauftemperatur ausgeschaltet.	<ul style="list-style-type: none"> ■ Heizkurve niedriger einstellen ■ Heizwasserdurchsatz erhöhen ■ Überströmventil weiter öffnen
High-pressure switch- off	The heat pump is switched off when the maximum flow temperature has been reached.	<ul style="list-style-type: none"> ■ Set lower heating curve ■ Increase heating water flow ■ Open overflow valve wider
Coupure haute pression	La pompe à chaleur a été mise hors service car la température de départ maximale a été atteinte.	<ul style="list-style-type: none"> ■ Régler la courbe de chauffe plus bas ■ Augmenter le débit d'eau chaude. ■ Ouvrir complètement la vanne de trop-plein
WP gesperrt	Wärmepumpe ist gesperrt	<ul style="list-style-type: none"> ■ Betriebsmodus durch mehrmaliges Drücken der Modustaste auf Automatik stellen ■ Externe Sperre am Regler (ID3,4) freigeben
HP blocked	The heat pump is blocked	<ul style="list-style-type: none"> ■ Set the operating mode to automatic by repeatedly pressing the modus button. ■ Release external block on the controller (ID3,4)
PAC bloquée	La pompe à chaleur est bloquée	<ul style="list-style-type: none"> ■ Régler le mode de fonctionnement sur Automatique en appuyant plusieurs fois sur la touche Mode ■ Blocage externe sur régulateur (ID3,4) débloqué
Temperaturdifferenz	Temperaturdifferenz zwischen Vor- und Rücklauf für die Abtauung zu groß oder negativ	<ul style="list-style-type: none"> ■ Heizwasserdurchsatz prüfen ■ Überströmventil und Pumpengröße prüfen ■ Vor- und Rücklauf vertauscht

Display	Erklärung / Explanation / Explication	Maßnahmen / Measures / Mesures à prendre
Temperature difference	Temperature difference between flow and return flow is too large or negative for defrosting	<ul style="list-style-type: none"> ■ Check heating water flow ■ Check overflow valve and pump size ■ Flow and return flow mixed up
Difference de temperature	Différence de température entre départ et retour pour le dégivrage trop grand ou négatif	<ul style="list-style-type: none"> ■ Contrôler le débit d'eau chaude ■ Contrôler la vanne trop-plein et la taille de la pompe ■ Départ et retour ont été permutés
Heissgasthermostat Last Verdichter		<ul style="list-style-type: none"> ■ Kundendienst ist zu informieren
Heating gas thermostat Compressor load		<ul style="list-style-type: none"> ■ Inform your after-sales service
Thermostat gaz chaud Charge compresseur		<ul style="list-style-type: none"> ■ Veuillez informer le service après-vente.
Motorschutz Primär	Stromaufnahme der Brunnen- oder Solepumpe über dem Schaltwert	<ul style="list-style-type: none"> ■ Einstellwert prüfen
Motor protection, Primary	Power consumption of the well pump or brine circulating pump above the switching value	<ul style="list-style-type: none"> ■ Check setting
Protection moteur primaire	Courant absorbé de la pompe de puits ou de la pompe à eau glycolée supérieur à la valeur de commutation	<ul style="list-style-type: none"> ■ Vérifier valeur de réglage
Durchfluss Brunnen	Durchflussschalter schaltet nicht	<ul style="list-style-type: none"> ■ Wasserdurchsatz Brunnen zu gering
Flow rate well	Flow rate switch does not switch	<ul style="list-style-type: none"> ■ Water flow through the well is insufficient
Debit du puits	Non enclenchement du commutateur de débit	<ul style="list-style-type: none"> ■ Débit d'eau puits trop faible
Störung Warmwasser	Erreichbare Warmwassertemperatur im Wärmepumpenbetrieb unter 35 °C	<ul style="list-style-type: none"> ■ Durchsatz Warmwasserumwälzpumpen zu gering ■ Rückschlagventil Heizung defekt
Hot water fault	Attainable hot water temperature during heat pump operation below 35 °C	<ul style="list-style-type: none"> ■ Hot water circulating pump flow is insufficient ■ Heating check valve is defective
Defaut eau chaude sanitaire	Température d'eau chaude sanitaire accessible pendant le fonctionnement de la pompe à chaleur en dessous de 35 °C	<ul style="list-style-type: none"> ■ Débit circulateur d'eau chaude sanitaire trop faible ■ Clapet anti-retour chauffage défectueux
Störung Frostschutzfühler	Vorlauftemperatur Heizung unter 7 °C	<ul style="list-style-type: none"> ■ Heizwassertemperatur anheben ■ Heizwasserdurchsatz erhöhen
Flow sensor fault	Heating flow temperature below 7 °C	<ul style="list-style-type: none"> ■ Raise heating water temperature ■ Increase heating water flow
Defaut sonde anti-gel	Température de départ chauffage inférieure à 7 °C	<ul style="list-style-type: none"> ■ Augmenter température eau de chauffage ■ Augmenter le débit d'eau de chauffage

Garantiebedingungen und Kundendienstadresse siehe
Montage- und Gebrauchsanweisung Wärmepumpe.

For the terms of the guarantee and after-sales service
addresses, please refer to the Installation and Operating
Instructions for Heat Pumps.

Pour les conditions de garantie et les adresses SAV, se référer
aux instructions de montage et d'utilisation de la pompe à
chaleur.

Irrtümer und Änderungen vorbehalten.
Subject to alterations and errors.
Sous réserve d'erreurs et modifications.